

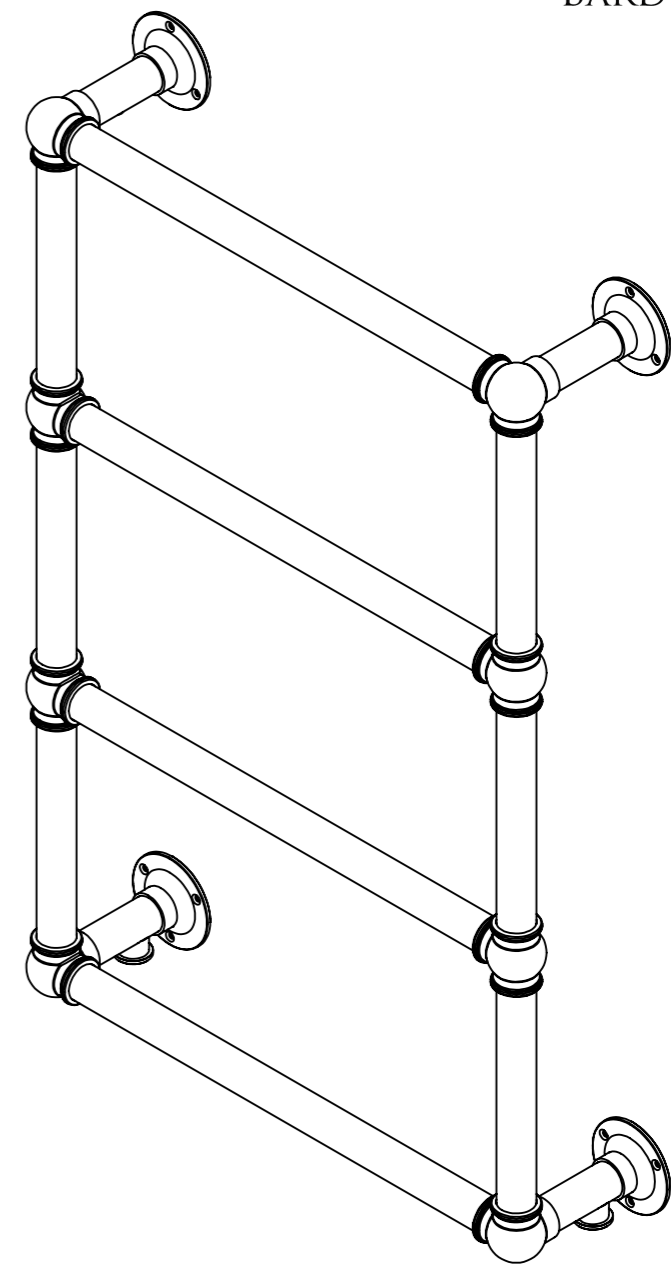

BARD & BRAZIER

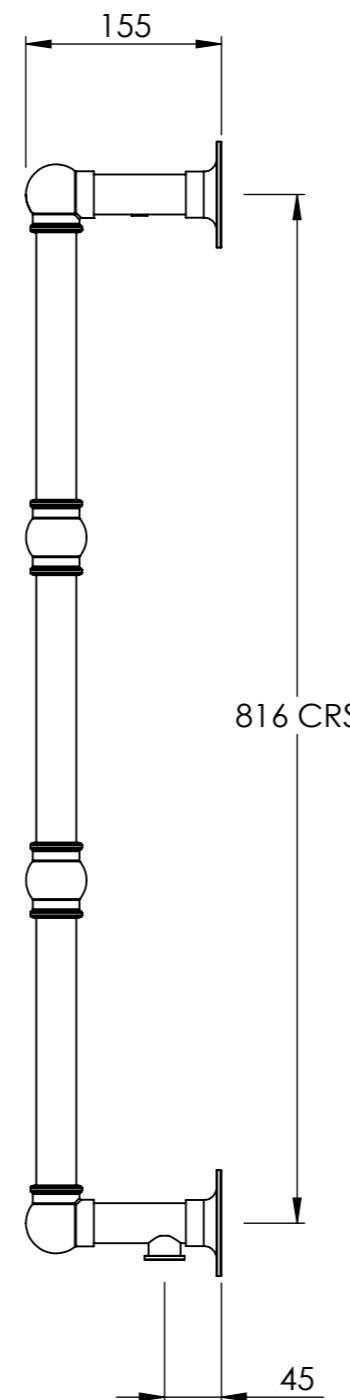
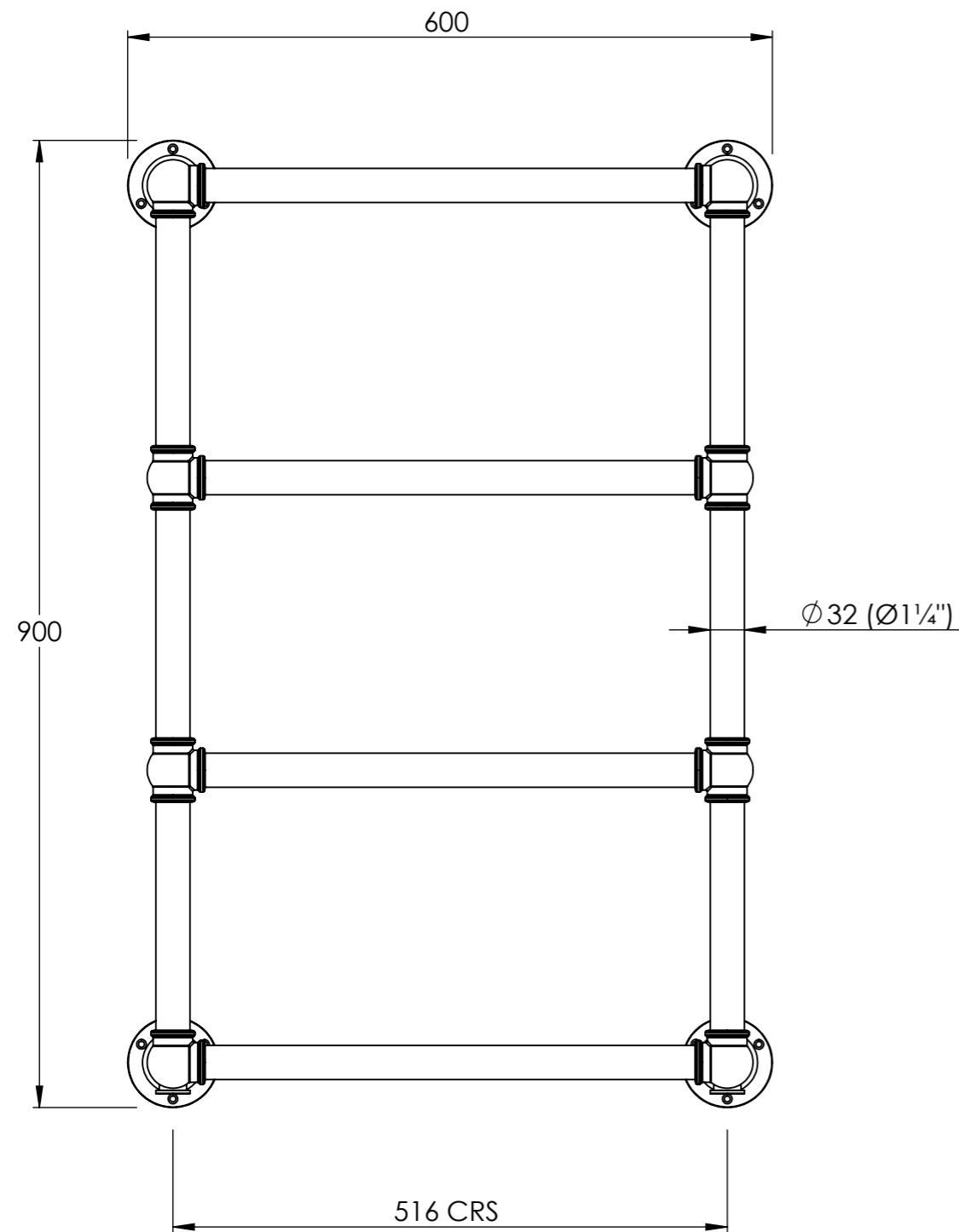

DO NOT SCALE DRAWING ALL DIMENSIONS ARE IN MILLIMETERS AND MAY VARY ± 5mm AS THEY ARE HANDMADE, HAND SOLDERED AND POLISHED  
 WE THEREFORE RECOMMEND THAT ANY INSTALLATION WORK BE CARRIED OUT UPON RECEIPT OF RAIL.

BTU/HR AT DELTA 60:	1013	TEST PRESSURE:	6 BAR
CONNECTIONS:	FI 1/2" BSP	MAX WORKING PRESSURE:	3 BAR
		MAX WORKING TEMPERATURE:	100°C
		HEAT OUTPUT DETERMINED IN ACCORDANCE WITH EN 442	
BARD & BRAZIER LIMITED T: +44 (0) 121 270 2222 MARSTON ROAD E: INFO@BARDBRAZIER.CO.UK WOLVERHAMPTON WEST MIDLANDS WWW.BARDBRAZIER.CO.UK WV2 4LX UK		<b>TITLE:</b> LA FAYETTE WALL MOUNTED TOWEL RAIL 900 x 600mm - HYDRONIC	
BARD & BRAZIER RAILS ARE MADE IN ENGLAND FROM HIGH QUALITY BRASS AND CAN BE USED ON OPEN OR CLOSED CIRCUITS		SCALE: 1:6	DATE: 13/04/2018
		PRODUCT CODE: <b>LFW90-60</b>	



BARD & BRAZIER

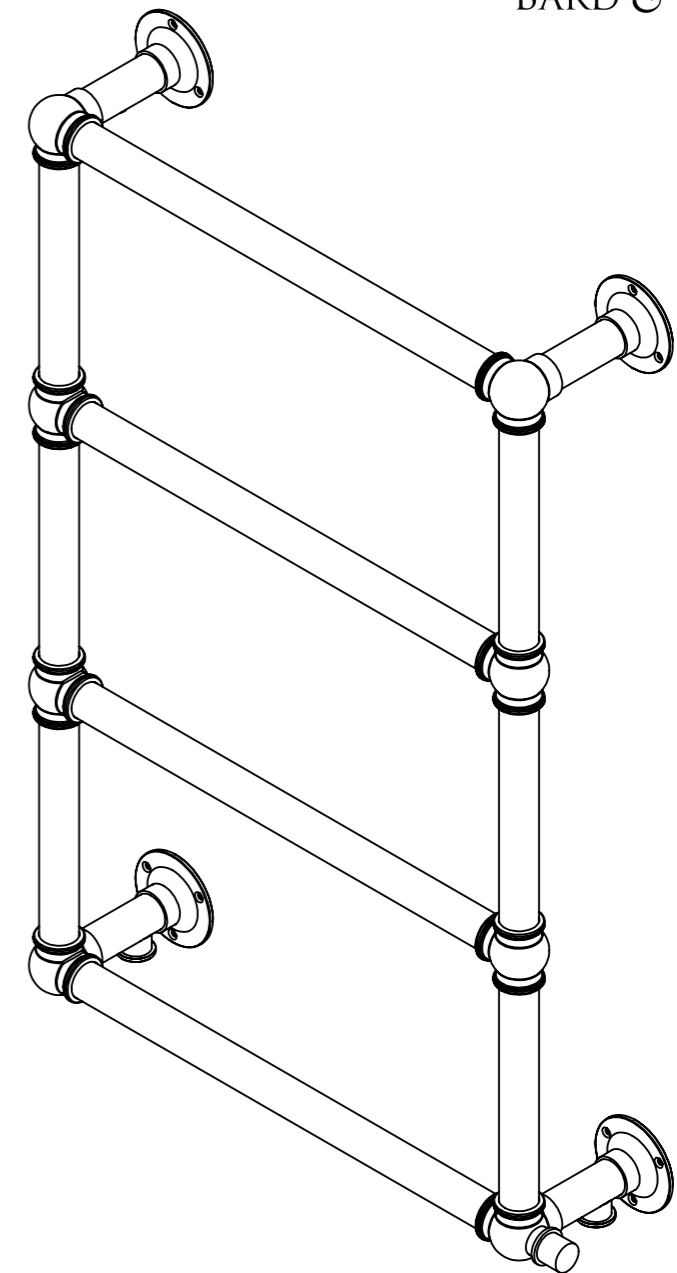
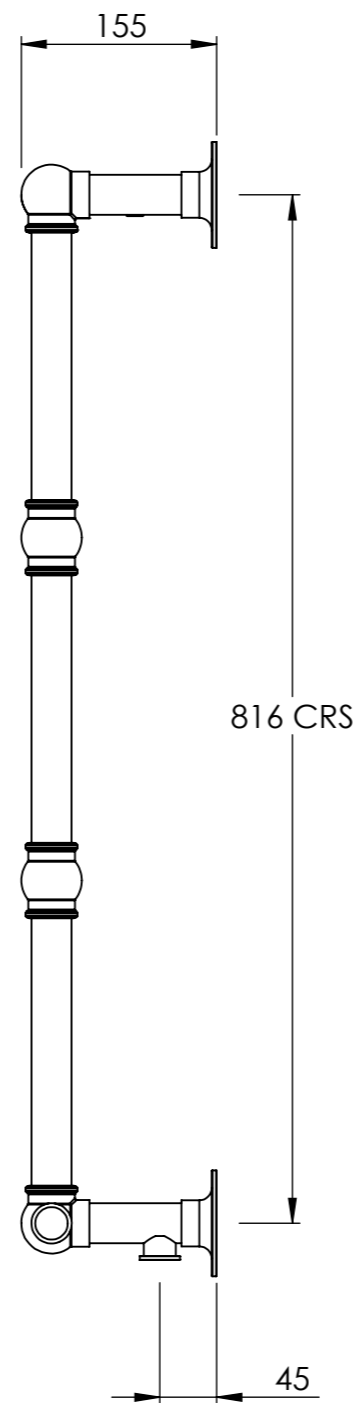
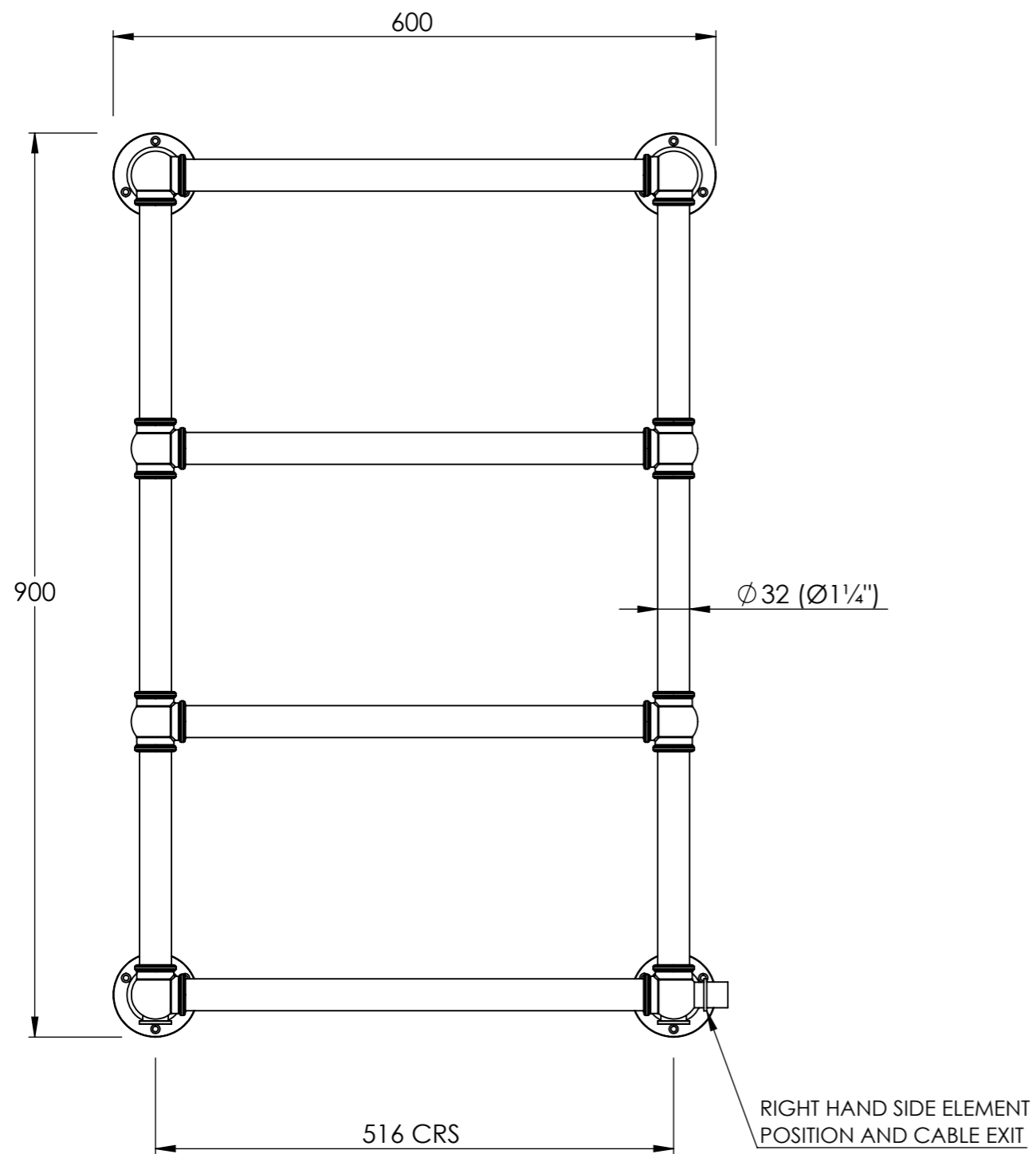

**REFER TO PAGE 2 FOR ELECTRICAL CONNECTION AND CABLE COVER SPECIFICATION**

DO NOT SCALE DRAWING ALL DIMENSIONS ARE IN MILLIMETERS AND MAY VARY ± 5mm AS THEY ARE HANDMADE, HAND SOLDERED AND POLISHED

WE THEREFORE RECOMMEND THAT ANY INSTALLATION WORK BE CARRIED OUT UPON RECEIPT OF RAIL.

BTU/HR AT DELTA 60:	1013	TEST PRESSURE:	6 BAR
ELECTRICAL ELEMENT WATTAGE:	125	MAX WORKING TEMPERATURE:	100°C
		CONNECTIONS	FI 1/2" BSP
HEAT OUTPUT DETERMINED IN ACCORDANCE WITH EN 442			
BARD & BRAZIER LIMITED MARSTON ROAD WOLVERHAMPTON WEST MIDLANDS WV2 4LX UK		T: +44 (0) 121 270 2222 E: INFO@BARDBRAZIER.CO.UK WWW.BARDBRAZIER.CO.UK	
TITLE: LA FAYETTE WALL MOUNTED TOWEL RAIL 900 x 600mm - DUAL FUEL			
BARD & BRAZIER RAILS ARE MADE IN ENGLAND FROM HIGH QUALITY BRASS AND CAN BE USED ON OPEN OR CLOSED CIRCUITS		SCALE:	DATE:
		1:6	13/04/2018
BARD & BRAZIER		PRODUCT CODE:	
		LFW90-60DF	



BARD & BRAZIER

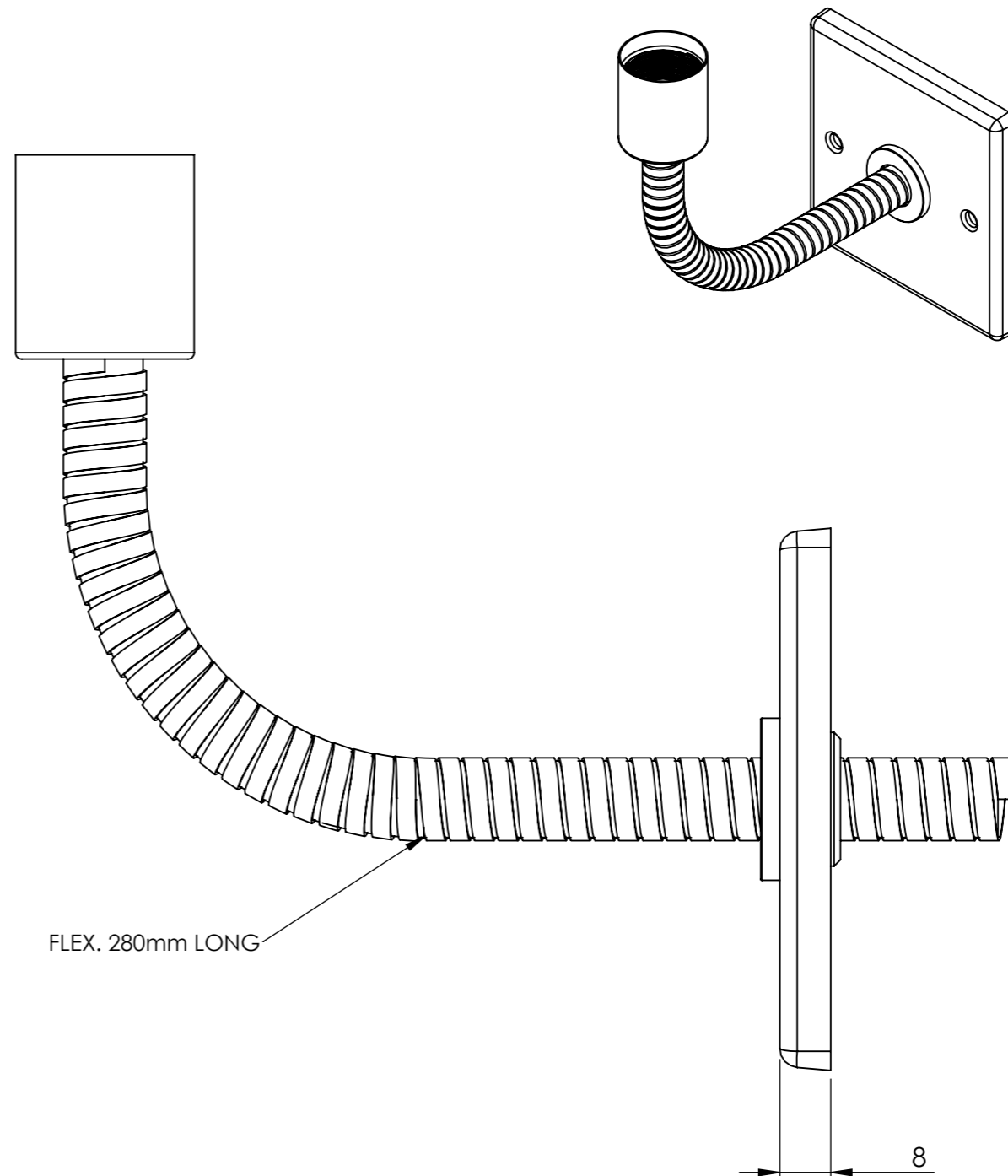
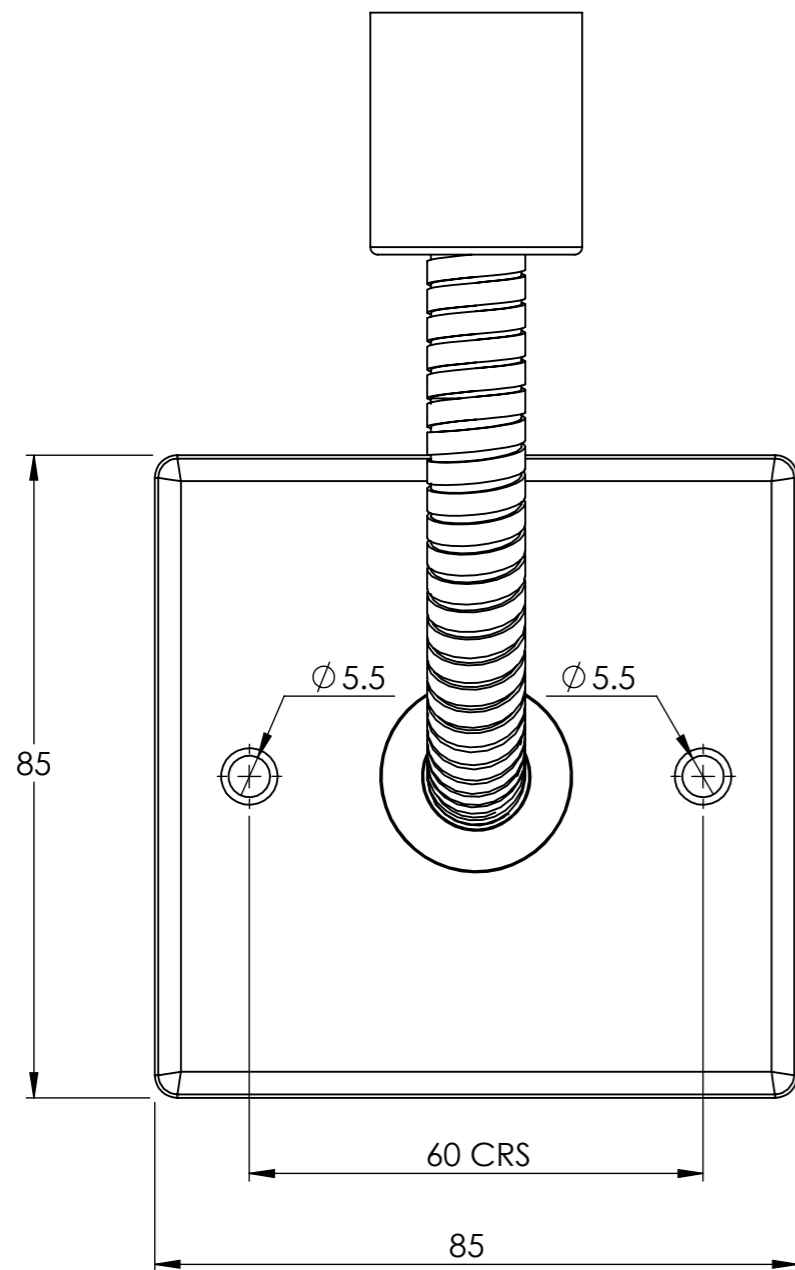

**FINISH TO MATCH WITH CHOSEN RAIL**

DO NOT SCALE DRAWING ALL DIMENSIONS ARE IN MILLIMETERS AND MAY VARY ± 5mm AS THEY ARE HANDMADE, HAND SOLDERED AND POLISHED

WE THEREFORE RECOMMEND THAT ANY INSTALLATION WORK BE CARRIED OUT UPON RECEIPT OF RAIL.

BARD & BRAZIER LIMITED T: +44 (0) 121 270 2222  
 MARSTON ROAD E: INFO@BARDBRAZIER.CO.UK  
 WOLVERHAMPTON  
 WEST MIDLANDS WWW.BARDBRAZIER.CO.UK  
 WV2 4LX  
 UK

BARD & BRAZIER RAILS ARE MADE IN ENGLAND FROM HIGH QUALITY BRASS

TITLE:  
ELECTRICAL KIT ASSEMBLY



SCALE: 1:1  
DATE: 07/08/2018

PRODUCT CODE:  
E201



BARD & BRAZIER

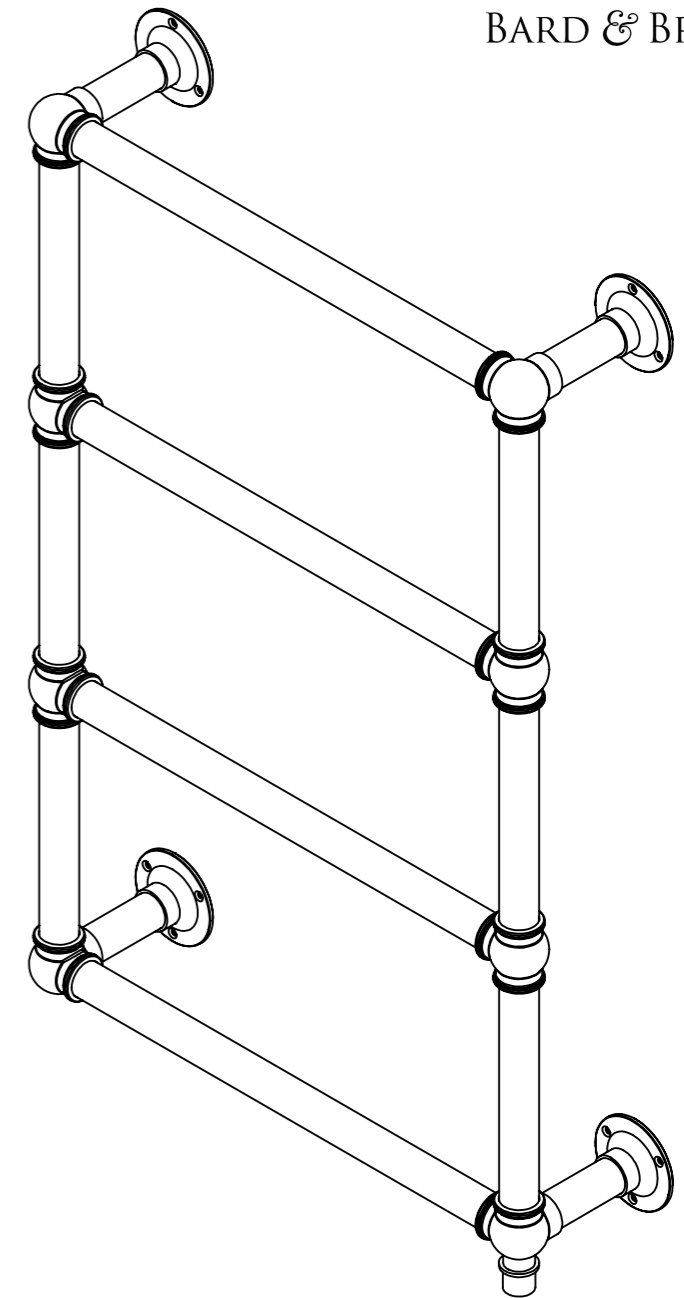
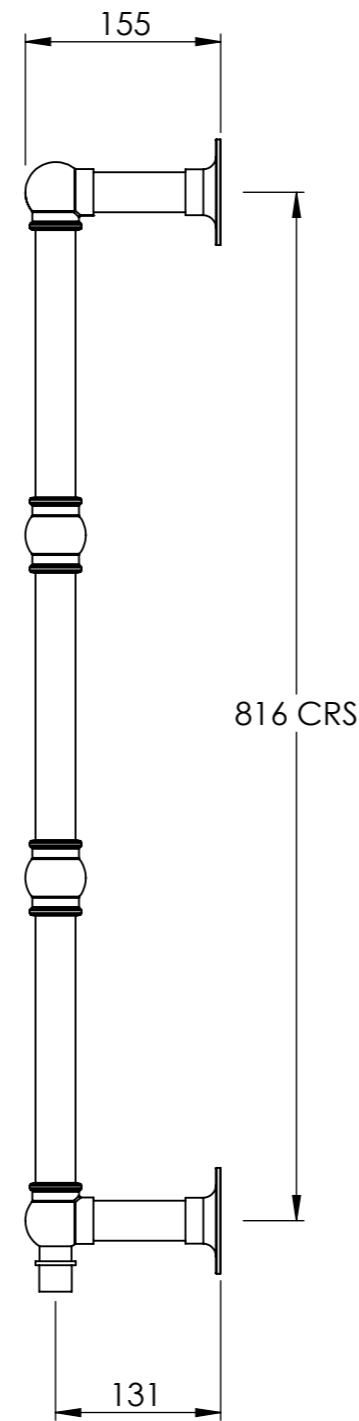
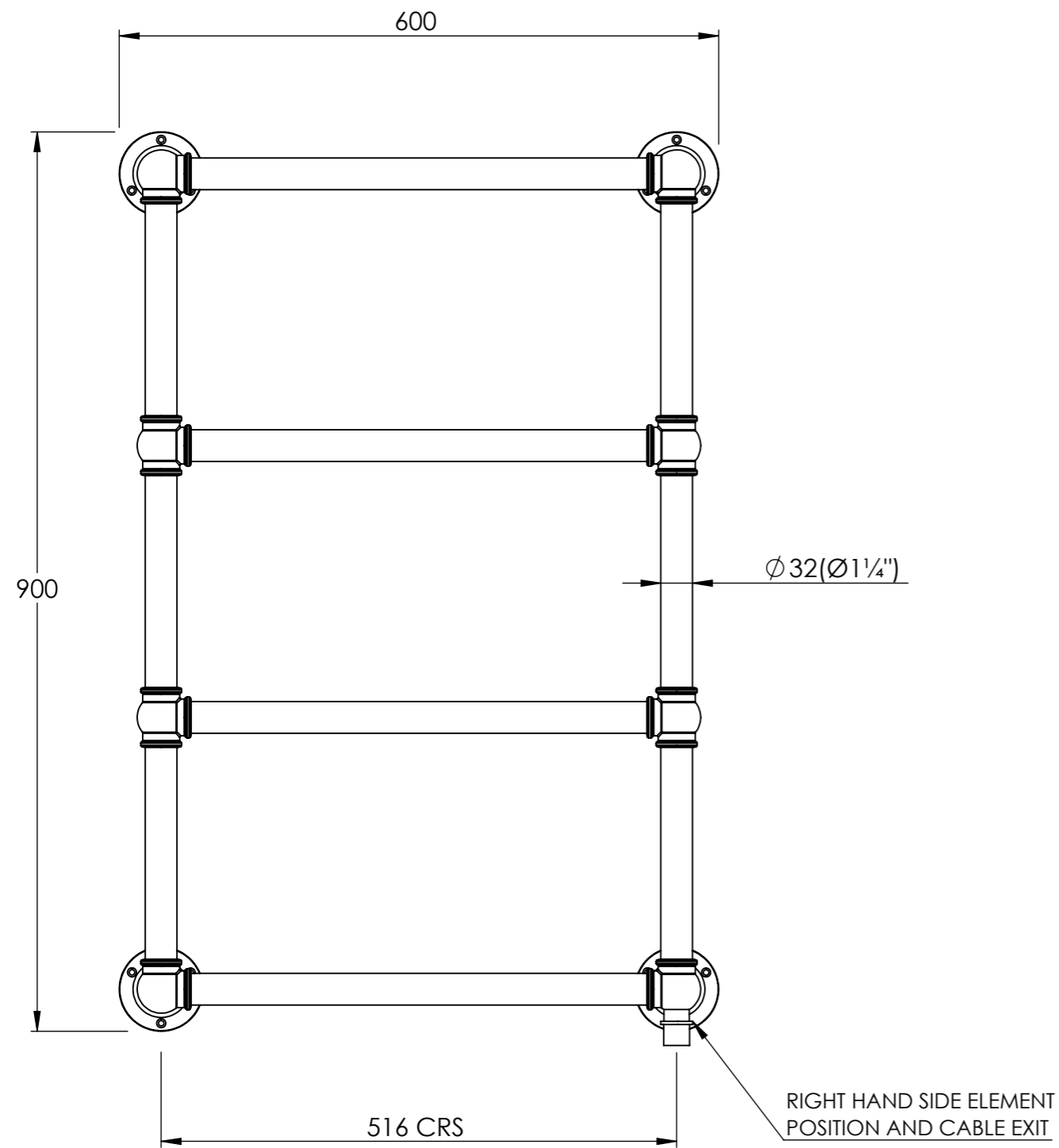

**REFER TO PAGE 2 FOR ELECTRICAL CONNECTION AND COVER PLATE SPECIFICATION**

DO NOT SCALE DRAWING ALL DIMENSIONS ARE IN MILLIMETERS AND MAY VARY  $\pm 5\text{mm}$  AS THEY ARE HANDMADE, HAND SOLDERED AND POLISHED  
WE THEREFORE RECOMMEND THAT ANY INSTALLATION WORK BE CARRIED OUT UPON RECEIPT OF RAIL.

BTU/HR AT DELTA 60:	1013	TEST PRESSURE:	6 BAR
ELECTRICAL ELEMENT WATTAGE:	125	MAX WORKING TEMPERATURE:	100°C
HEAT OUTPUT DETERMINED IN ACCORDANCE WITH EN 442			
BARD & BRAZIER LIMITED MARSTON ROAD WOLVERHAMPTON WEST MIDLANDS WV2 4LX UK		T: +44 (0) 121 270 2222 E: INFO@BARDBRAZIER.CO.UK WWW.BARDBRAZIER.CO.UK	
<b>TITLE:</b> LA FAYETTE WALL MOUNTED TOWEL RAIL 900 x 600mm - SEALED ELECTRIC			
 BARD & BRAZIER		SCALE:	DATE:
		1:6	13/04/2018
BARD & BRAZIER RAILS ARE MADE IN ENGLAND FROM HIGH QUALITY BRASS		PRODUCT CODE: LFW90-60SE	



BARD & BRAZIER

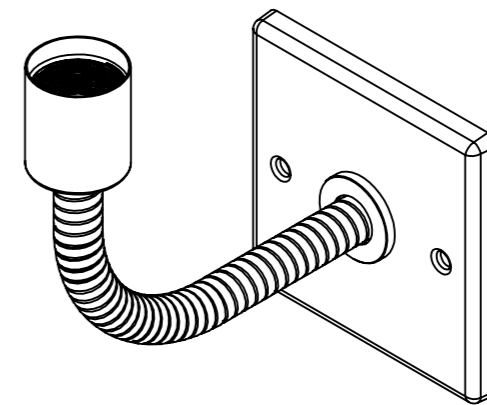
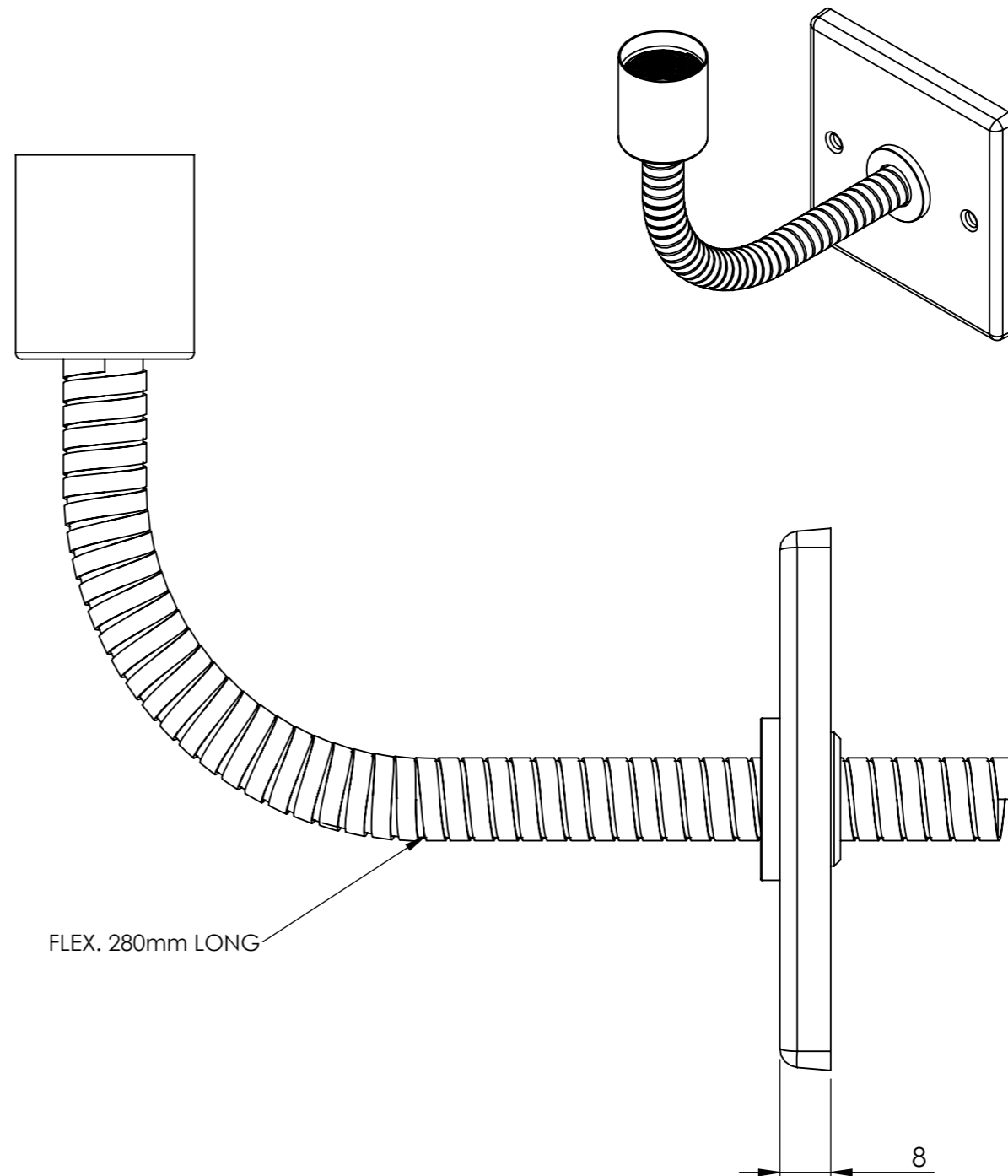
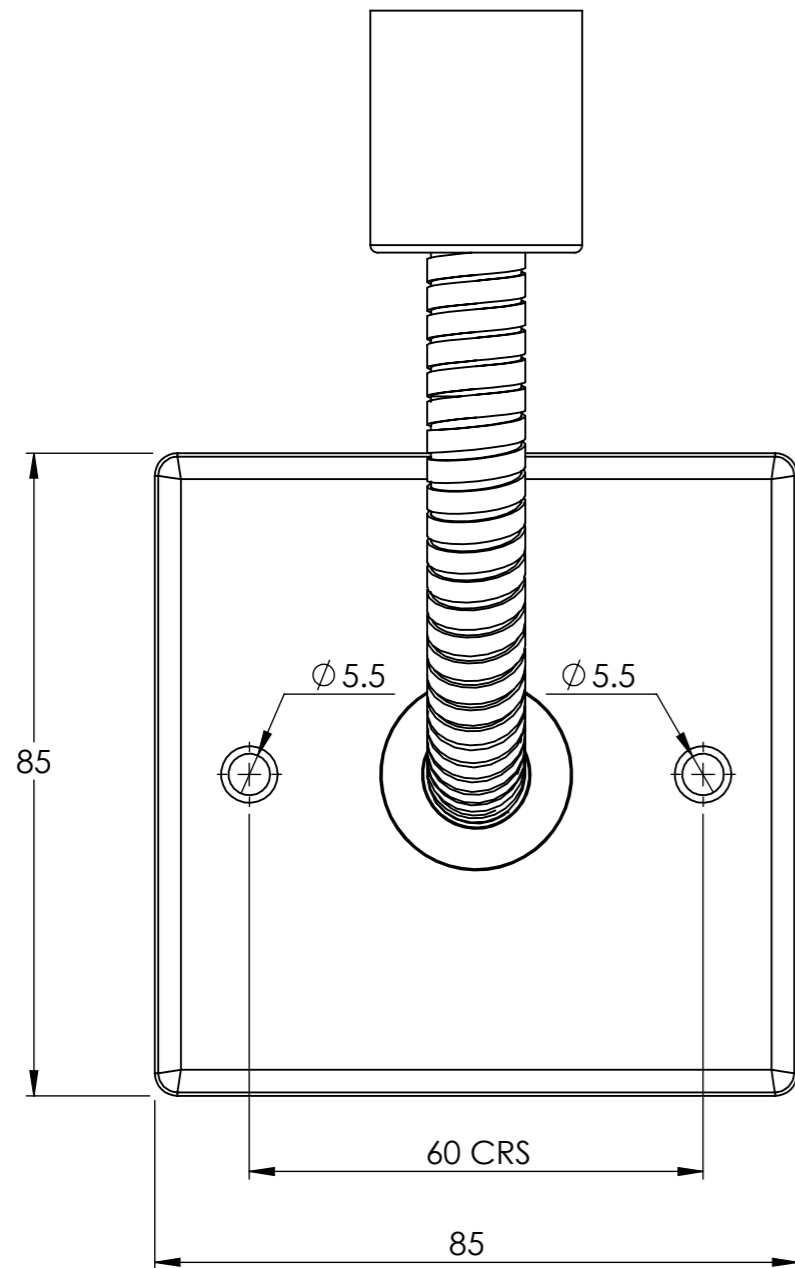

**FINISH TO MATCH WITH CHOSEN RAIL**

DO NOT SCALE DRAWING ALL DIMENSIONS ARE IN MILLIMETERS AND MAY VARY ± 5mm AS THEY ARE HANDMADE, HAND SOLDERED AND POLISHED

WE THEREFORE RECOMMEND THAT ANY INSTALLATION WORK BE CARRIED OUT UPON RECEIPT OF RAIL.

BARD & BRAZIER LIMITED T: +44 (0) 121 270 2222  
 MARSTON ROAD E: INFO@BARDBRAZIER.CO.UK  
 WOLVERHAMPTON  
 WEST MIDLANDS WWW.BARDBRAZIER.CO.UK  
 WV2 4LX  
 UK

BARD & BRAZIER RAILS ARE MADE IN ENGLAND FROM HIGH QUALITY BRASS

TITLE:

ELECTRICAL KIT ASSEMBLY



SCALE: 1:1 DATE: 07/08/2018

PRODUCT CODE: E201