

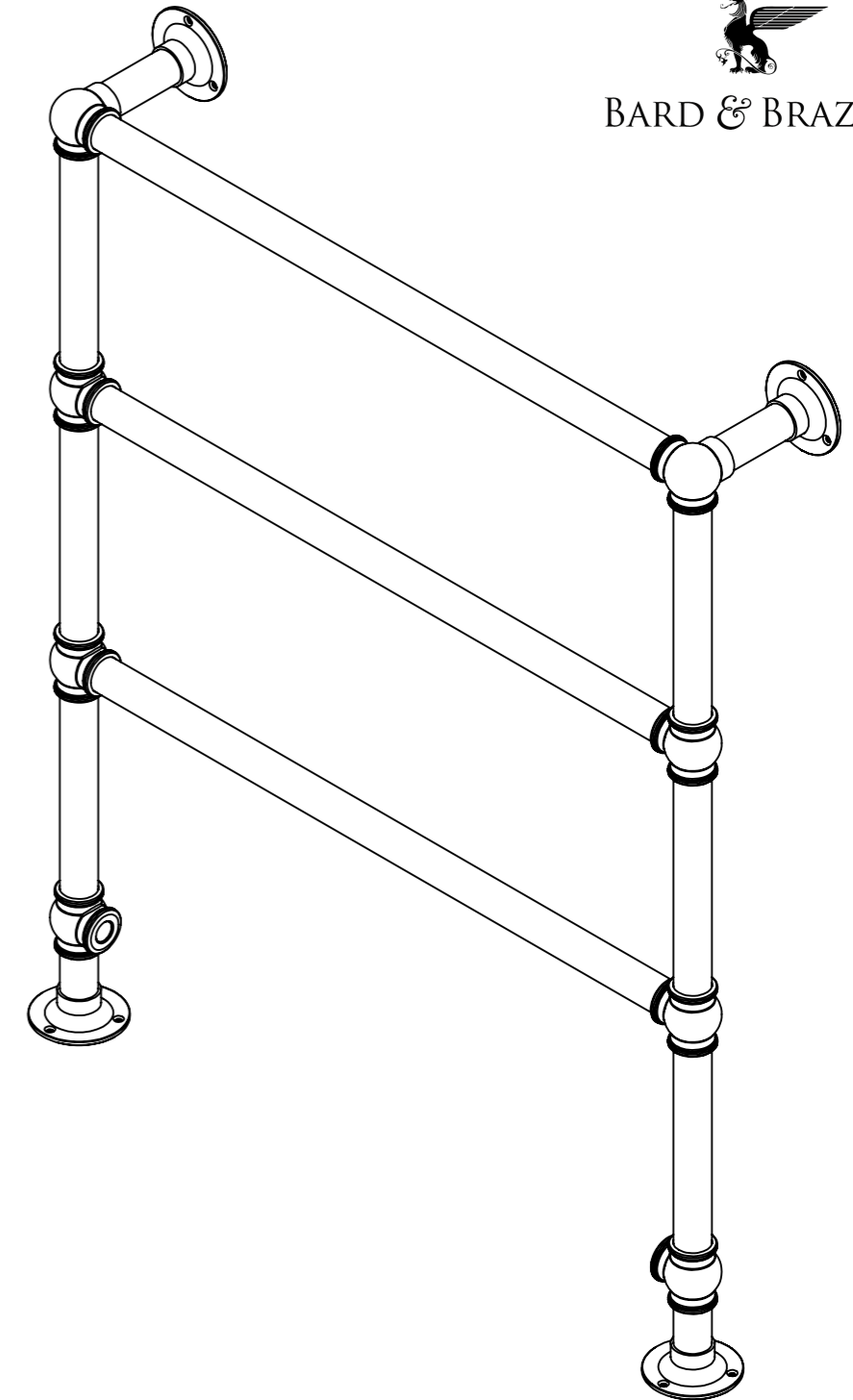

BARD & BRAZIER

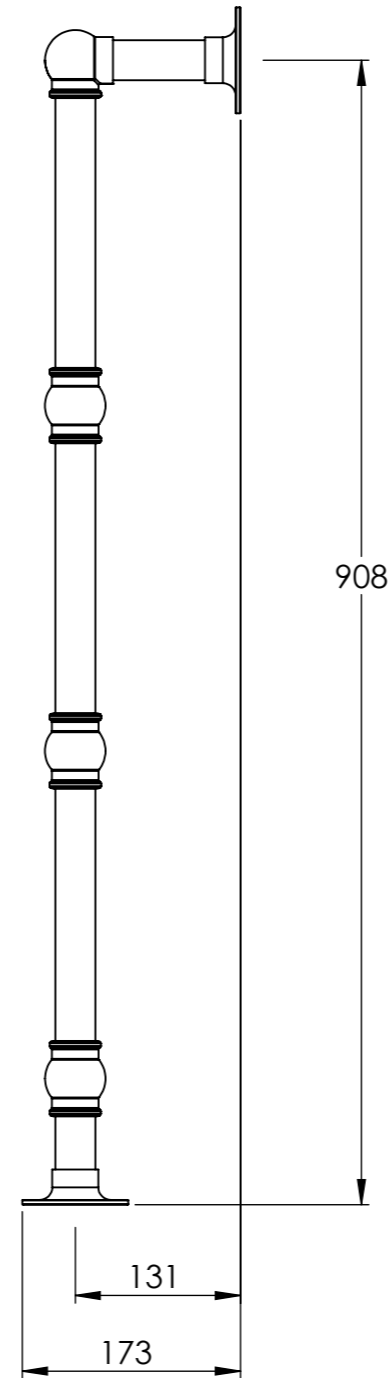
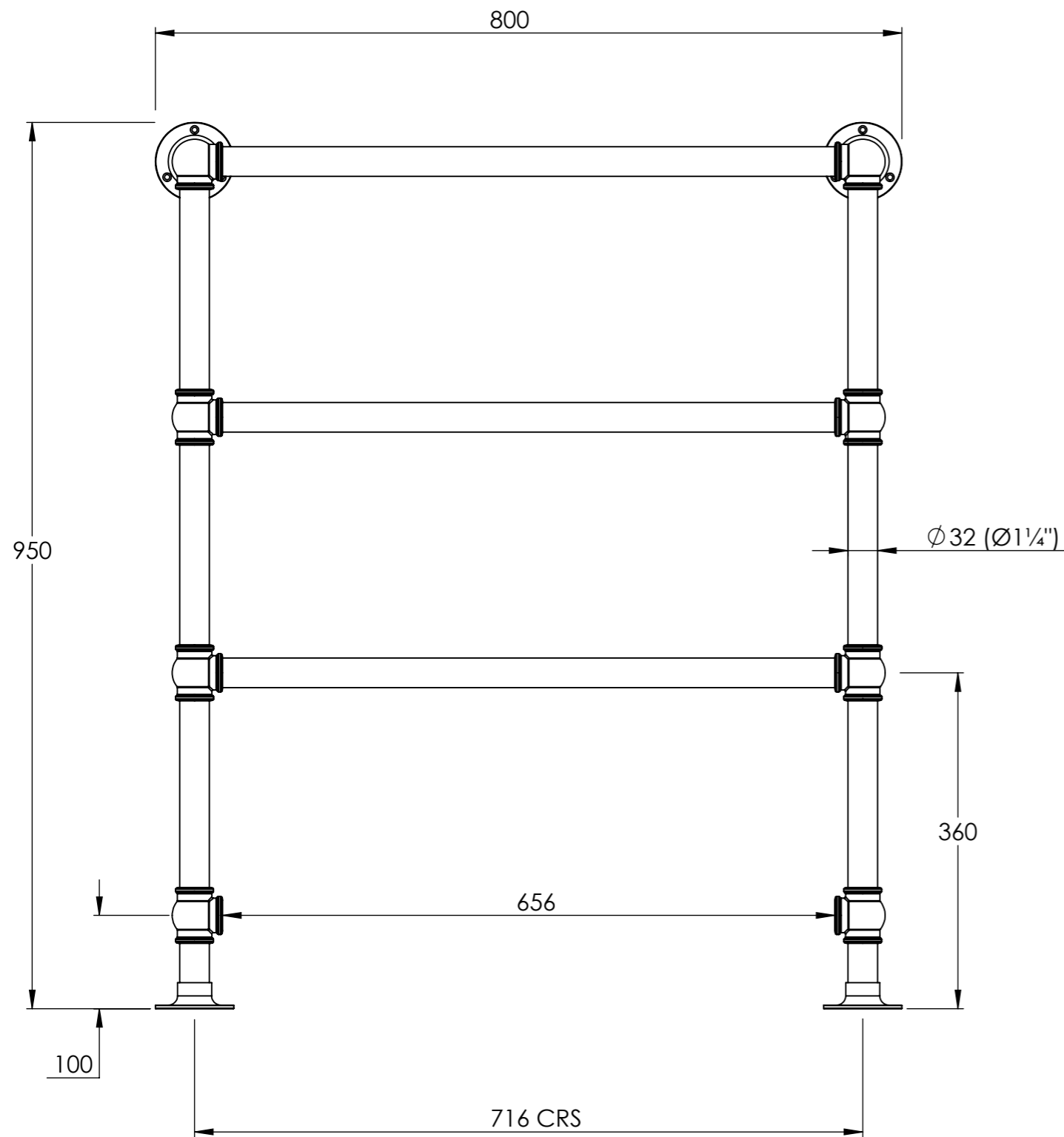

DO NOT SCALE DRAWING ALL DIMENSIONS ARE IN MILLIMETERS AND MAY VARY $\pm 5\text{mm}$ AS THEY ARE HANDMADE, HAND SOLDERED AND POLISHED
 WE THEREFORE RECOMMEND THAT ANY INSTALLATION WORK BE CARRIED OUT UPON RECEIPT OF RAIL.

BTU/HR AT DELTA 60:	1109	TEST PRESSURE:	6 BAR
CONNECTIONS:	FI 1/2" BSP	MAX WORKING PRESSURE:	3 BAR
		MAX WORKING TEMPERATURE:	100°C
HEAT OUTPUT DETERMINED IN ACCORDANCE WITH EN 442			
BARD & BRAZIER LIMITED MARSTON ROAD WOLVERHAMPTON WEST MIDLANDS WV2 4LX UK		T: +44 (0) 121 270 2222 E: INFO@BARDBRAZIER.CO.UK WWW.BARDBRAZIER.CO.UK	
TITLE: LA FAYETTE FLOOR MOUNTED TOWEL RAIL 950 x 800mm - HYDRONIC			
BARD & BRAZIER		SCALE:	DATE:
		1:6	13/04/2018
		PRODUCT CODE: LFF95-80	

BARD & BRAZIER RAILS ARE MADE IN ENGLAND
 FROM HIGH QUALITY BRASS AND CAN BE USED
 ON OPEN OR CLOSED CIRCUITS



BARD & BRAZIER

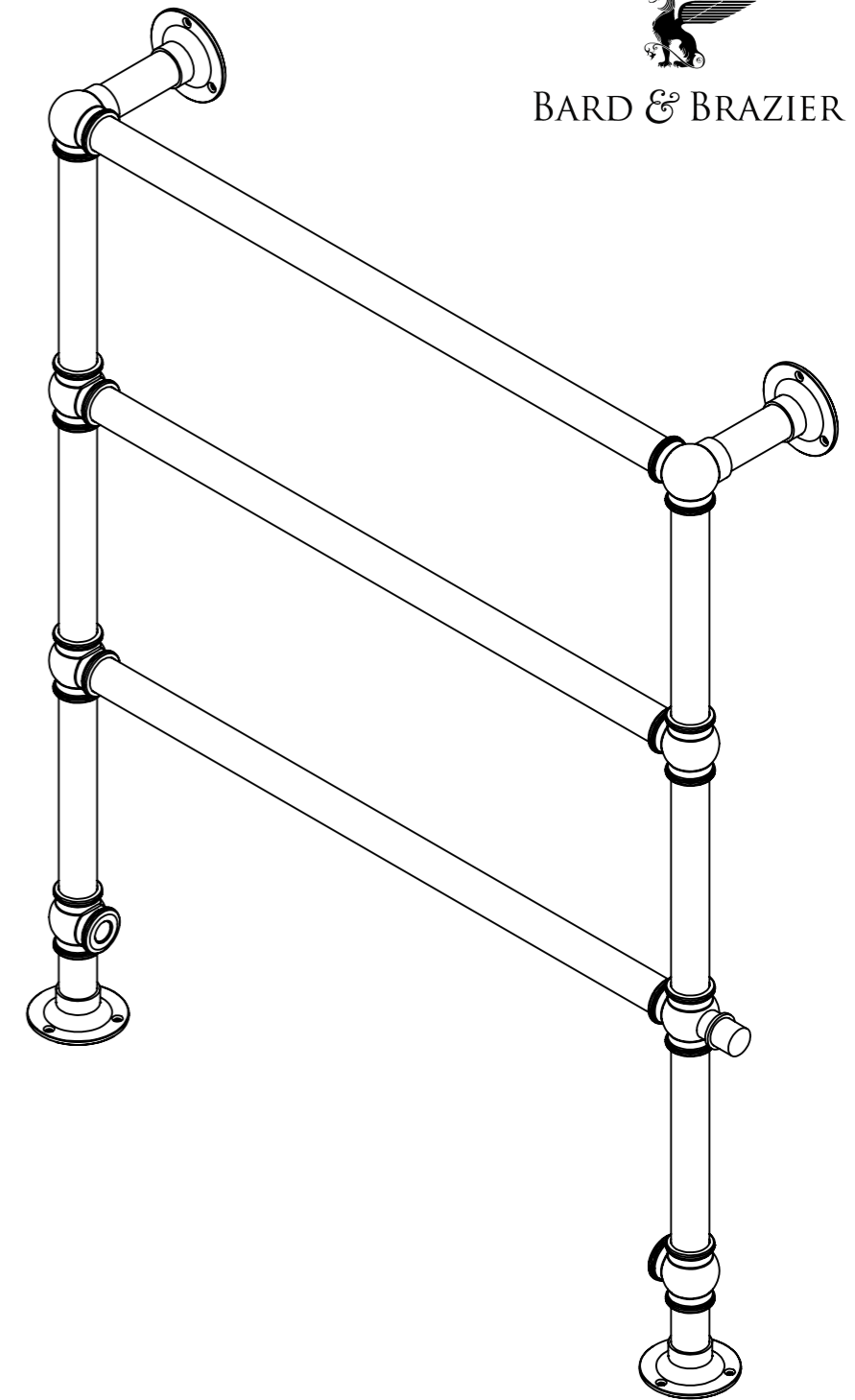
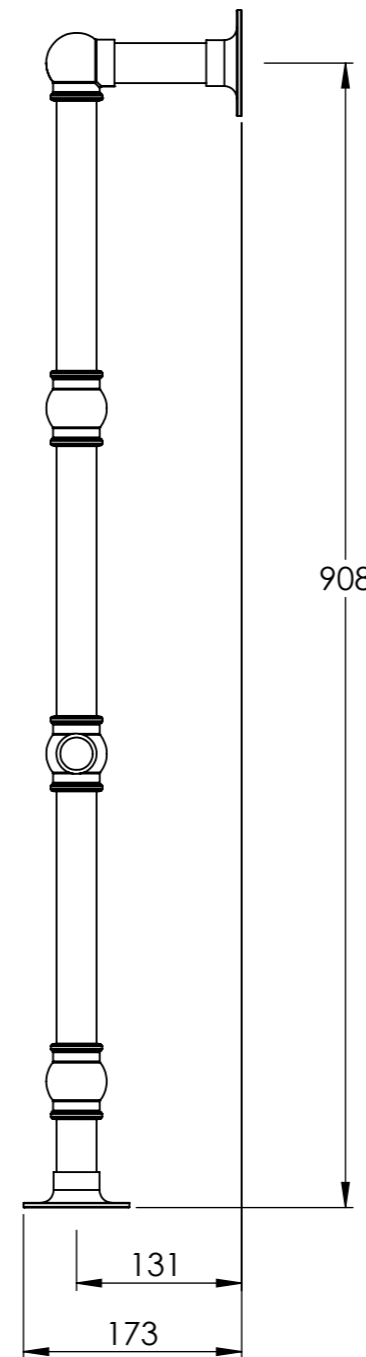
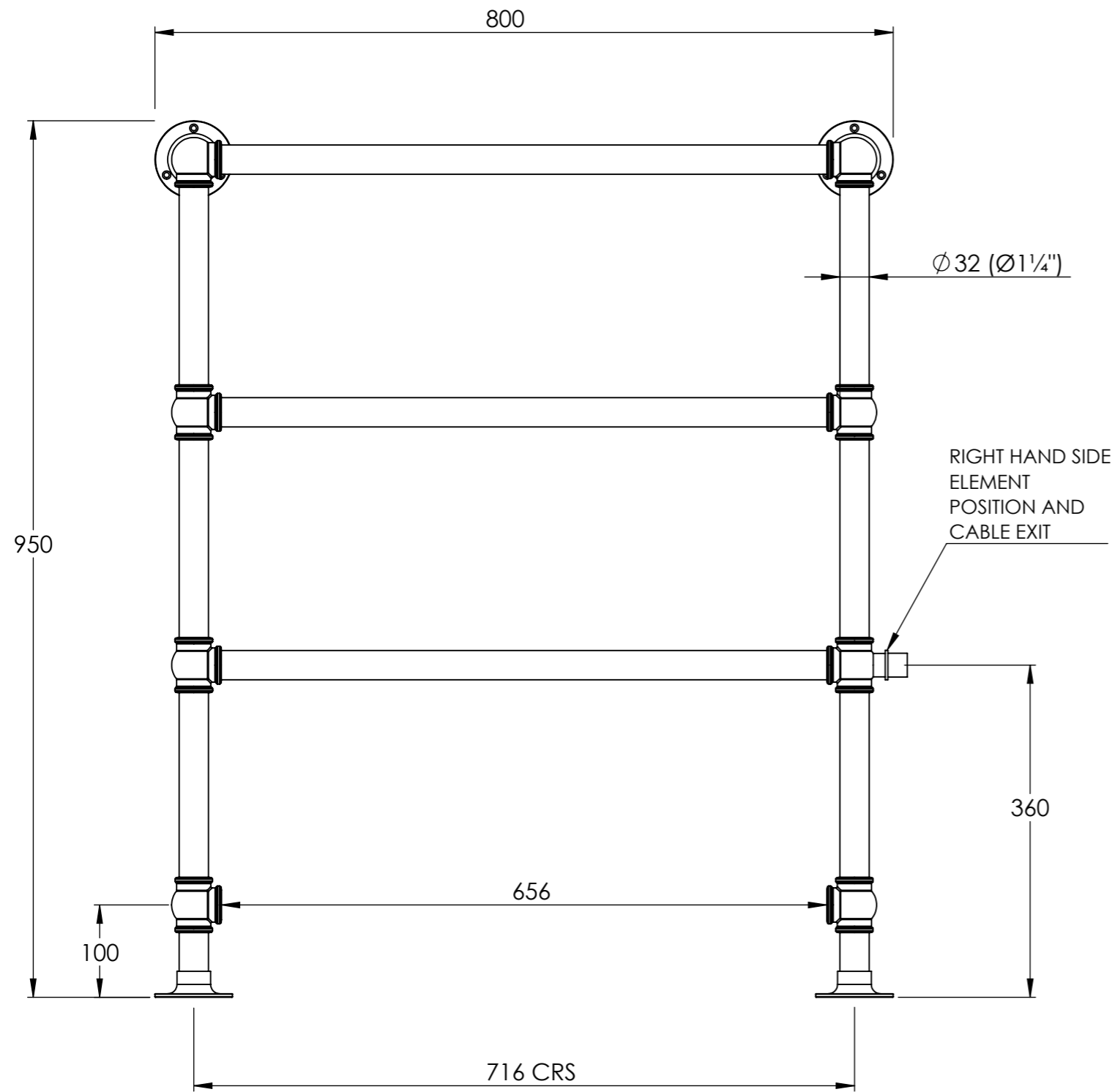

REFER TO PAGE 2 FOR ELECTRICAL CONNECTION AND CABLE COVER SPECIFICATION

DO NOT SCALE DRAWING ALL DIMENSIONS ARE IN MILLIMETERS AND MAY VARY ± 5mm AS THEY ARE HANDMADE, HAND SOLDERED AND POLISHED

WE THEREFORE RECOMMEND THAT ANY INSTALLATION WORK BE CARRIED OUT UPON RECEIPT OF RAIL.

BTU/HR AT DELTA 60:	1109	TEST PRESSURE:	6 BAR
ELECTRICAL ELEMENT WATTAGE:	125	MAX WORKING TEMPERATURE:	100°C
		CONNECTIONS	FI 1/2" BSP
HEAT OUTPUT DETERMINED IN ACCORDANCE WITH EN 442			
BARD & BRAZIER LIMITED MARSTON ROAD WOLVERHAMPTON WEST MIDLANDS WV2 4LX UK		T: +44 (0) 121 270 2222 E: INFO@BARDBRAZIER.CO.UK WWW.BARDBRAZIER.CO.UK	
TITLE: LA FAYETTE FLOOR MOUNTED TOWEL RAIL 950 x 800mm - DUAL FUEL			
BARD & BRAZIER RAILS ARE MADE IN ENGLAND FROM HIGH QUALITY BRASS AND CAN BE USED ON OPEN OR CLOSED CIRCUITS		SCALE:	DATE:
		1:6	13/04/2018
		PRODUCT CODE:	
		LFF95-80DF	



BARD & BRAZIER

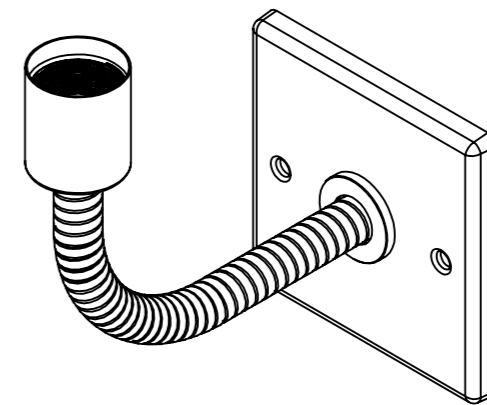
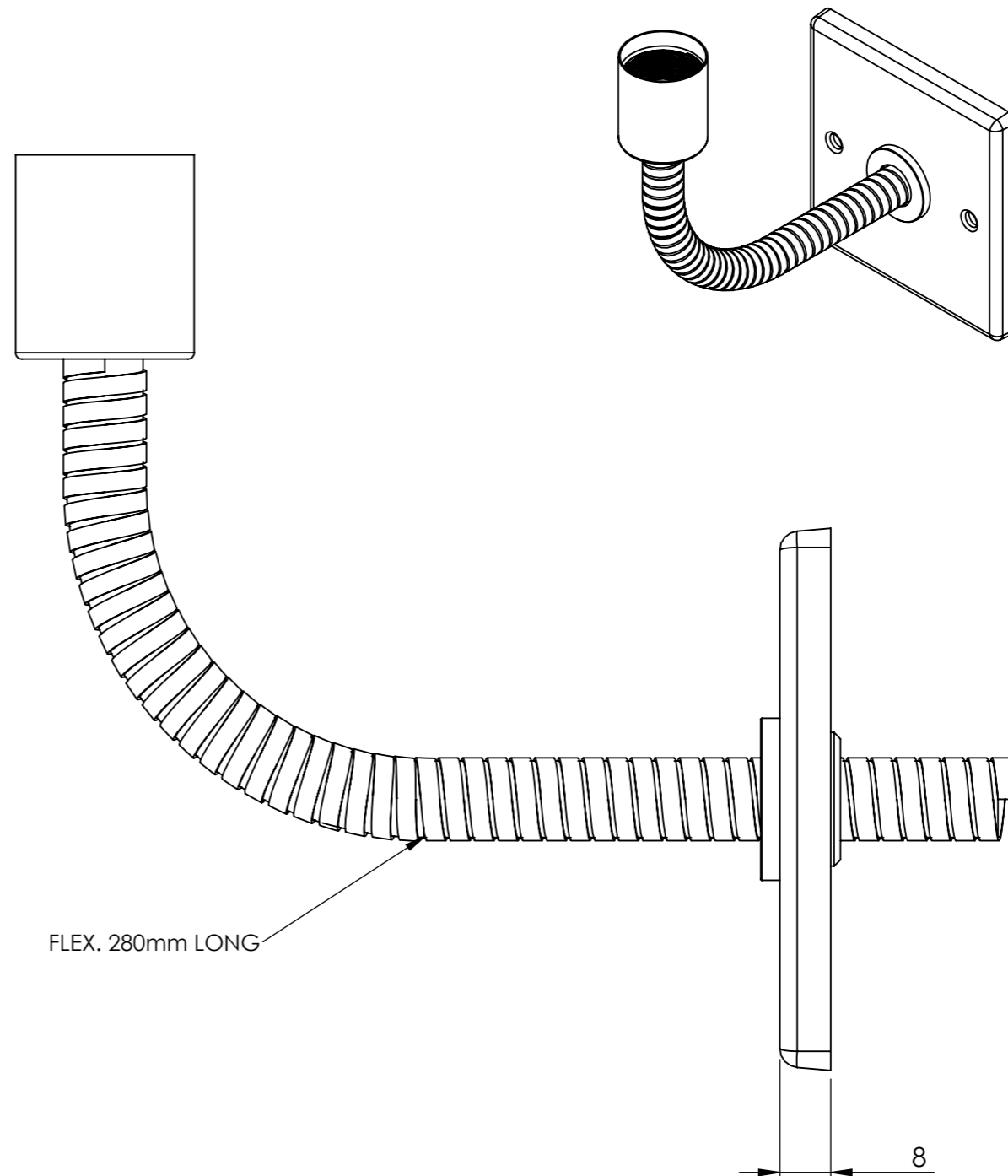
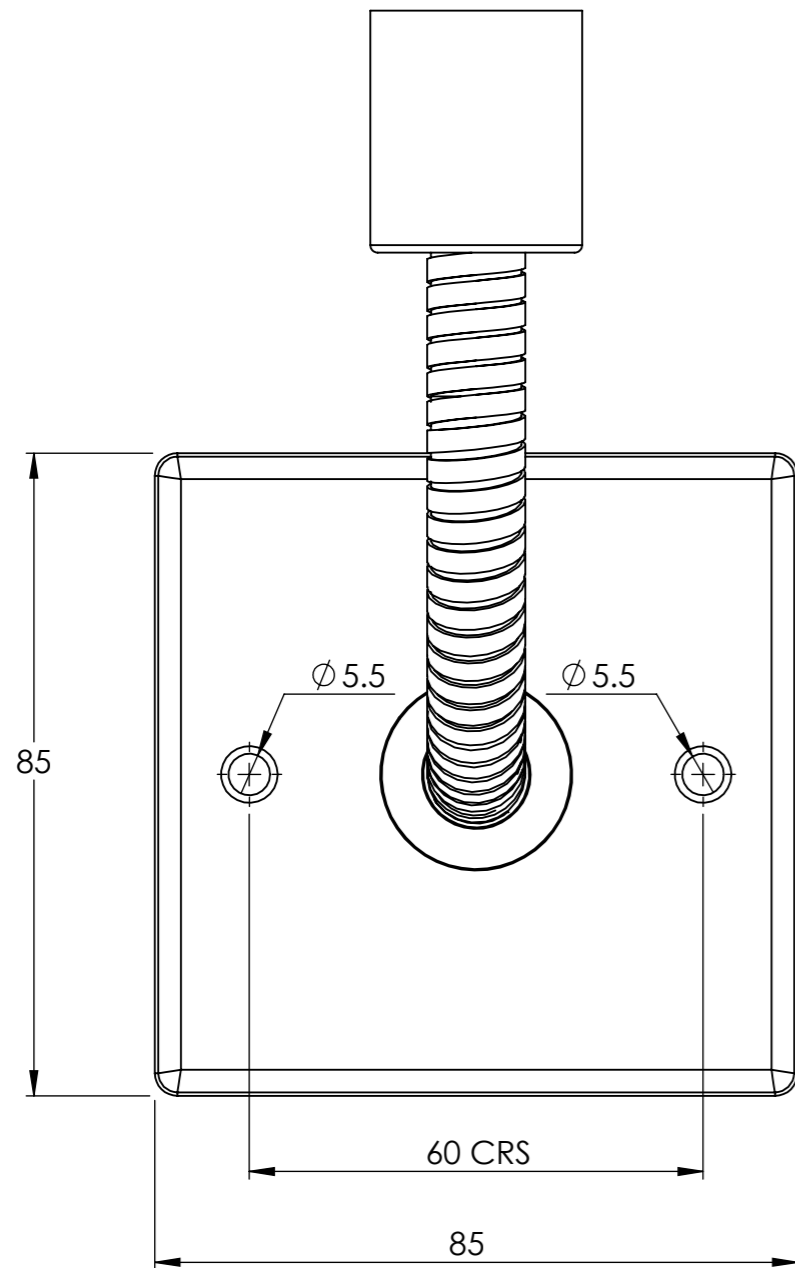

FINISH TO MATCH WITH CHOSEN RAIL

DO NOT SCALE DRAWING ALL DIMENSIONS ARE IN MILLIMETERS AND MAY VARY ± 5mm AS THEY ARE HANDMADE, HAND SOLDERED AND POLISHED

WE THEREFORE RECOMMEND THAT ANY INSTALLATION WORK BE CARRIED OUT UPON RECEIPT OF RAIL.

BARD & BRAZIER LIMITED T: +44 (0) 121 270 2222
 MARSTON ROAD E: INFO@BARDBRAZIER.CO.UK
 WOLVERHAMPTON
 WEST MIDLANDS WWW.BARDBRAZIER.CO.UK
 WV2 4LX
 UK

BARD & BRAZIER RAILS ARE MADE IN ENGLAND FROM HIGH QUALITY BRASS

TITLE:
ELECTRICAL KIT ASSEMBLY



SCALE: 1:1 DATE: 07/08/2018

PRODUCT CODE:
E201



BARD & BRAZIER

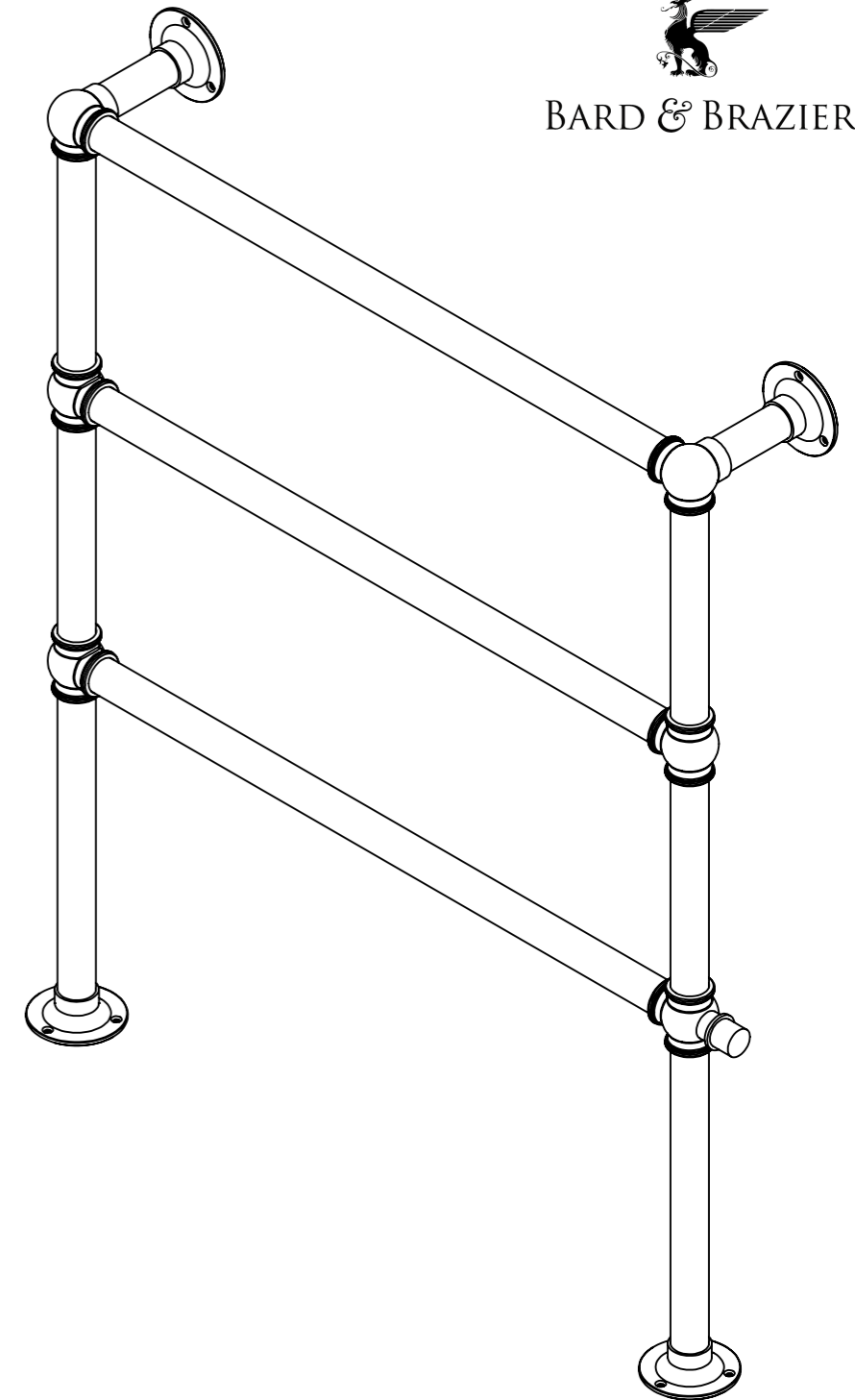
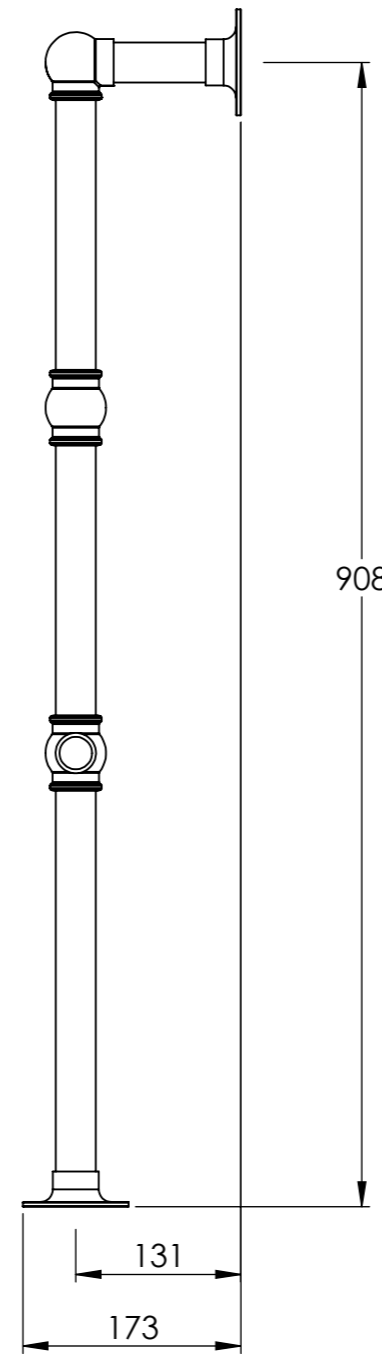
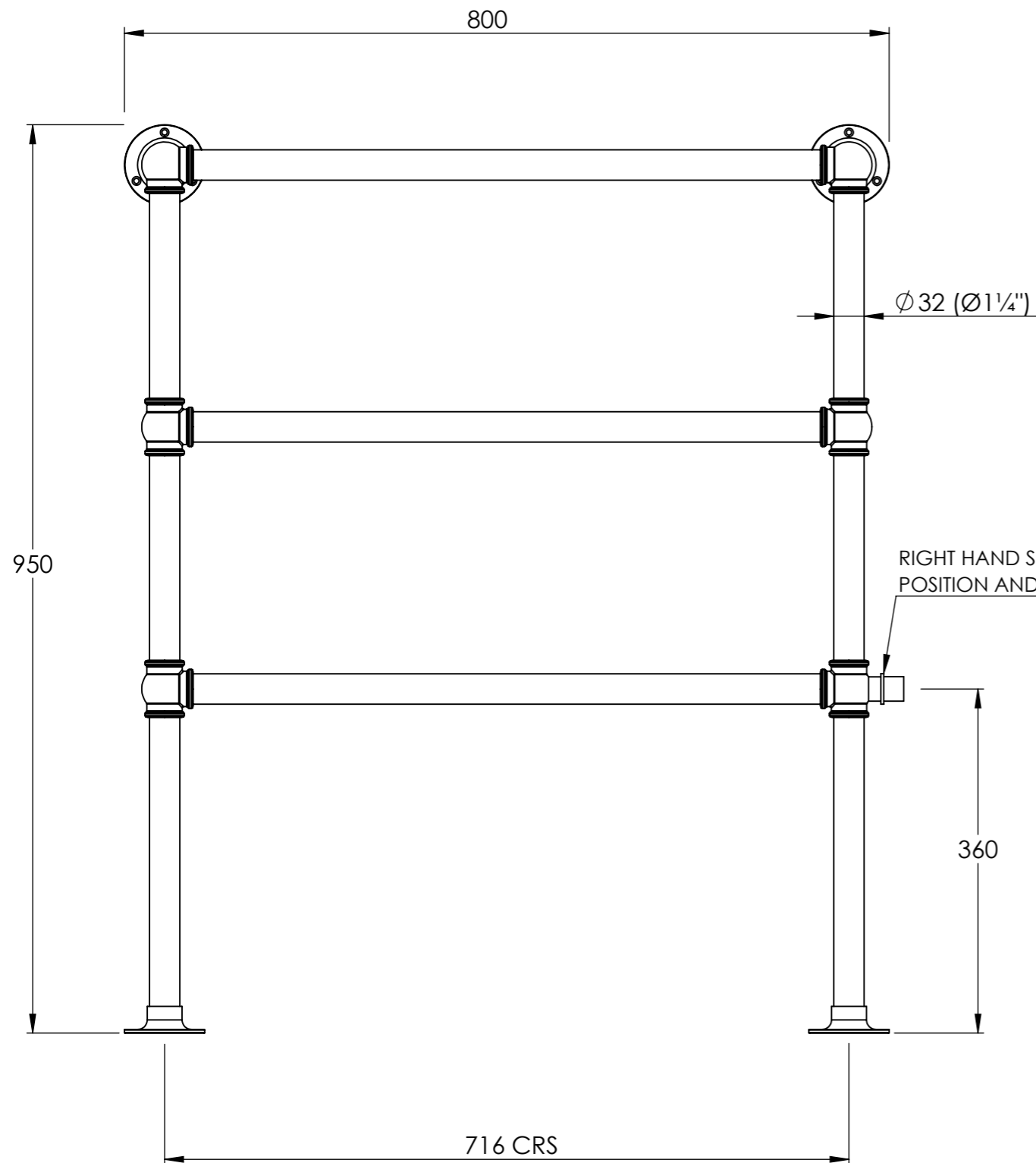

REFER TO PAGE 2 FOR ELECTRICAL CONNECTION AND COVER PLATE SPECIFICATION

DO NOT SCALE DRAWING ALL DIMENSIONS ARE IN MILLIMETERS AND MAY VARY ± 5mm AS THEY ARE HANDMADE, HAND SOLDERED AND POLISHED

WE THEREFORE RECOMMEND THAT ANY INSTALLATION WORK BE CARRIED OUT UPON RECEIPT OF RAIL.

BTU/HR AT DELTA 60:	1109	TEST PRESSURE:	6 BAR
ELECTRICAL ELEMENT WATTAGE:	125	MAX WORKING TEMPERATURE:	100°C
HEAT OUTPUT DETERMINED IN ACCORDANCE WITH EN 442			
BARD & BRAZIER LIMITED MARSTON ROAD WOLVERHAMPTON WEST MIDLANDS WV2 4LX UK		T: +44 (0) 121 270 2222 E: INFO@BARDBRAZIER.CO.UK WWW.BARDBRAZIER.CO.UK	
TITLE: LA FAYETTE FLOOR MOUNTED TOWEL RAIL 950 x 800mm - SEALED ELECTRIC			
 BARD & BRAZIER		SCALE:	DATE:
		1:6	13/04/2018
BARD & BRAZIER RAILS ARE MADE IN ENGLAND FROM HIGH QUALITY BRASS		PRODUCT CODE: LFF95-80SE	



BARD & BRAZIER

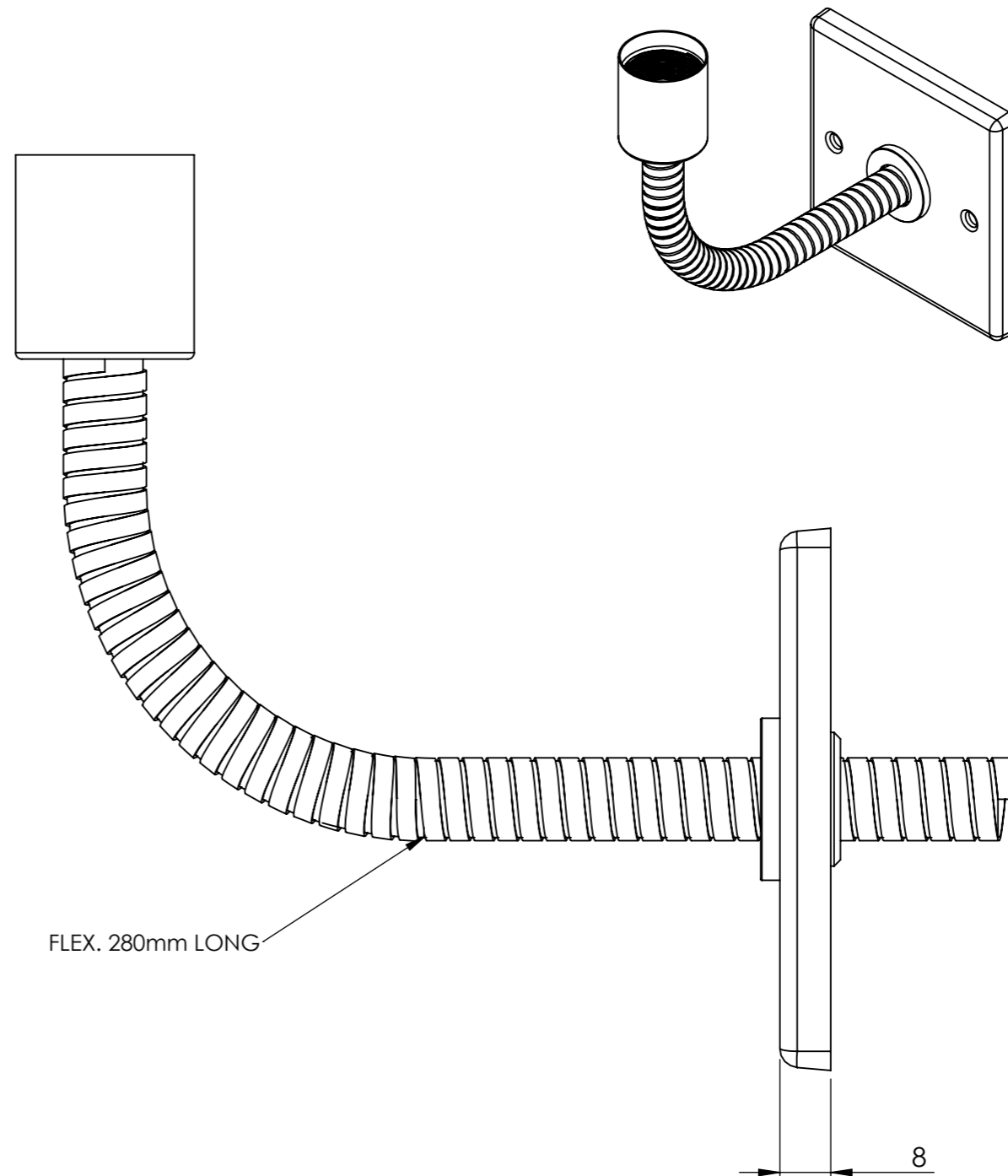
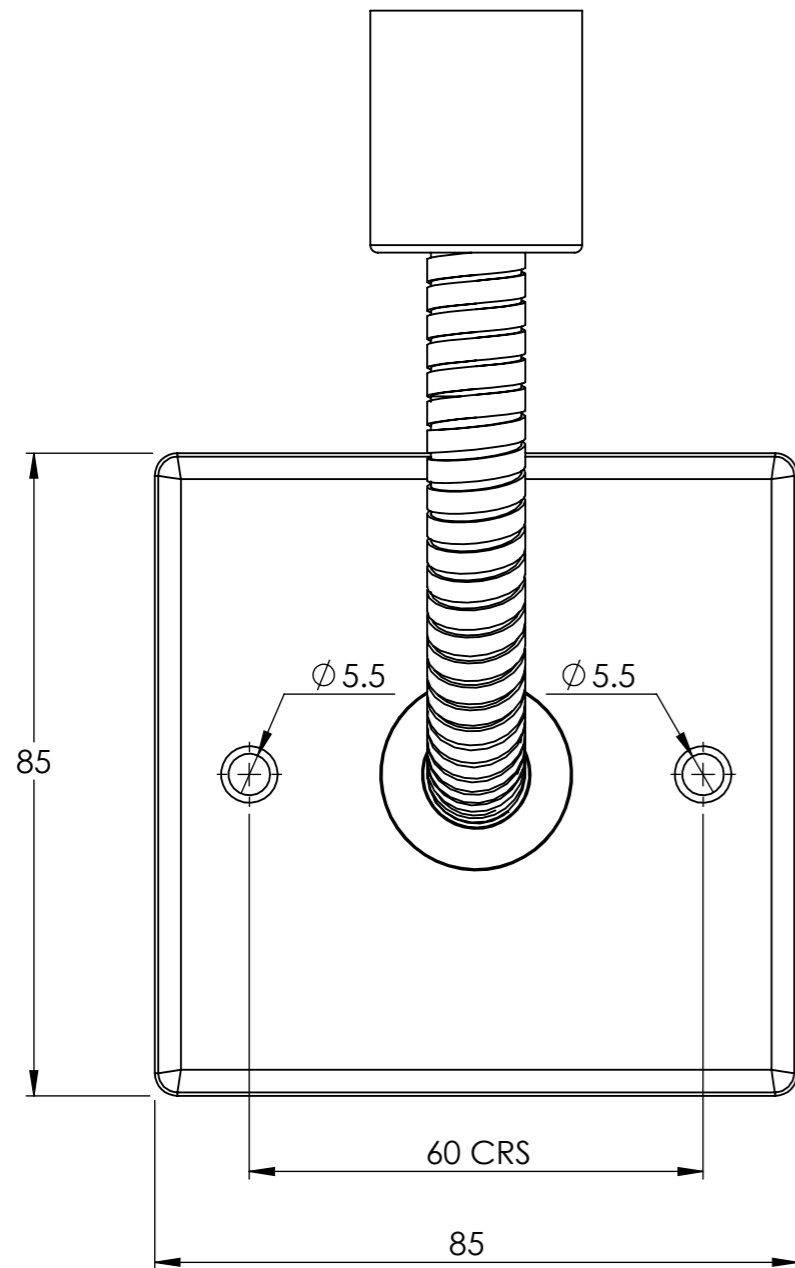

FINISH TO MATCH WITH CHOSEN RAIL

DO NOT SCALE DRAWING ALL DIMENSIONS ARE IN MILLIMETERS AND MAY VARY ± 5 mm AS THEY ARE HANDMADE, HAND SOLDERED AND POLISHED

WE THEREFORE RECOMMEND THAT ANY INSTALLATION WORK BE CARRIED OUT UPON RECEIPT OF RAIL.

BARD & BRAZIER LIMITED T: +44 (0) 121 270 2222
 MARSTON ROAD E: INFO@BARDBRAZIER.CO.UK
 WOLVERHAMPTON
 WEST MIDLANDS WWW.BARDBRAZIER.CO.UK
 WV2 4LX
 UK

BARD & BRAZIER RAILS ARE MADE IN ENGLAND FROM HIGH QUALITY BRASS

TITLE:
ELECTRICAL KIT ASSEMBLY



SCALE: 1:1 DATE: 07/08/2018

PRODUCT CODE:
E201