

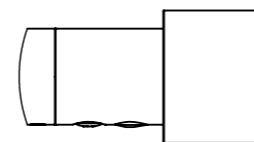

BARD & BRAZIER

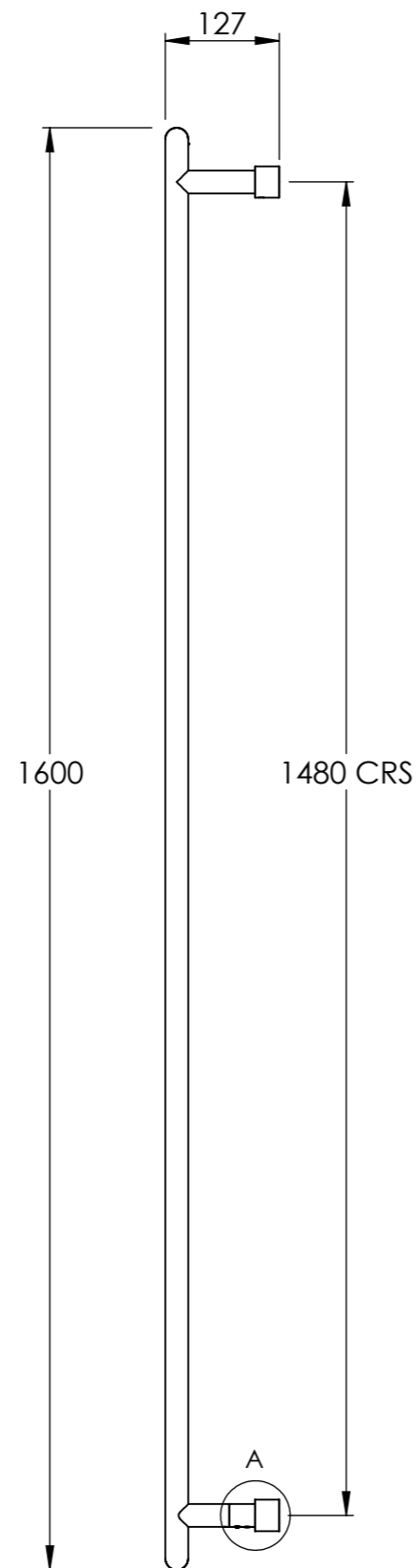
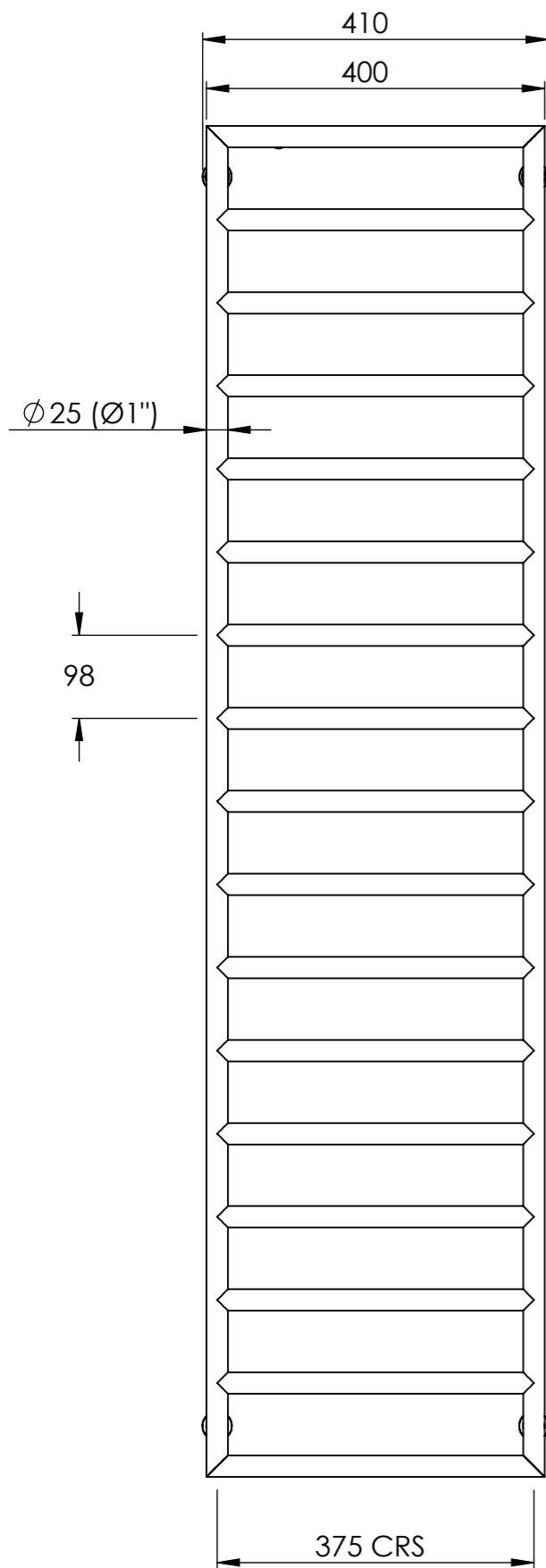

DETAIL A
SCALE 1 : 2

PATENTED INTEGRATED VALVES
INSTALLED ON LOWER WALL RETURNS

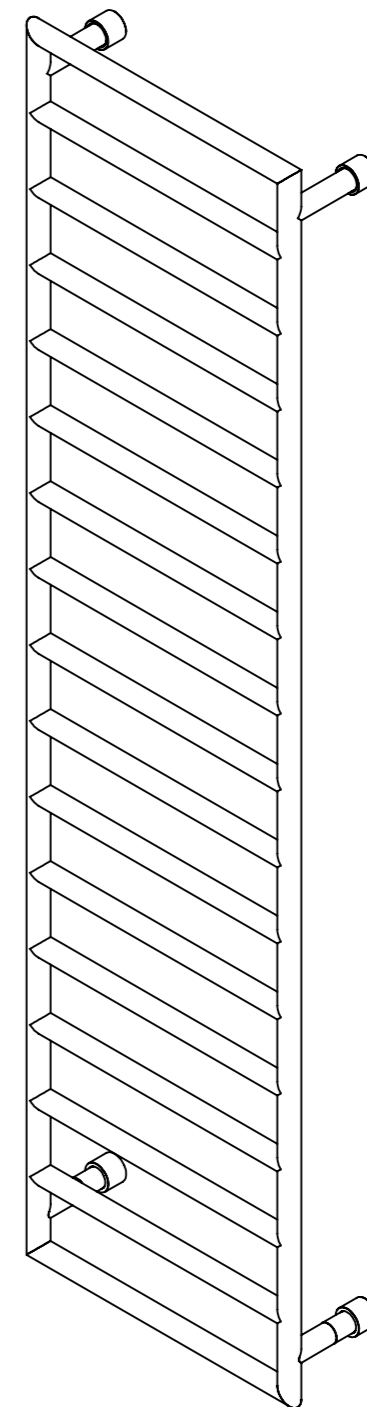

DO NOT SCALE DRAWING ALL DIMENSIONS ARE IN MILLIMETERS AND MAY VARY ± 5mm AS THEY ARE HANDMADE, HAND SOLDERED AND POLISHED
WE THEREFORE RECOMMEND THAT ANY INSTALLATION WORK BE CARRIED OUT UPON RECEIPT OF RAIL.

BTU/HR AT DELTA 60:	1580	TEST PRESSURE:	6 BAR
CONNECTIONS:	15mm COMPRESSION	MAX WORKING PRESSURE:	3 BAR
		MAX WORKING TEMPERATURE:	100°C
HEAT OUTPUT DETERMINED IN ACCORDANCE WITH EN 442			
BARD & BRAZIER LIMITED MARSTON ROAD WOLVERHAMPTON WEST MIDLANDS WV2 4LX UK		T: +44 (0) 121 270 2222 E: INFO@BARDBRAZIER.CO.UK WWW.BARDBRAZIER.CO.UK	
		TITLE: D-RAIL 17 BAR TOWEL WARMER 1600 x 400mm - HYDRONIC	
		SCALE: 1:8	DATE: 16/04/2018
		PRODUCT CODE: DRW160-40	

BARD & BRAZIER RAILS ARE MADE IN ENGLAND
FROM HIGH QUALITY BRASS AND CAN BE USED
ON OPEN OR CLOSED CIRCUITS





BARD & BRAZIER

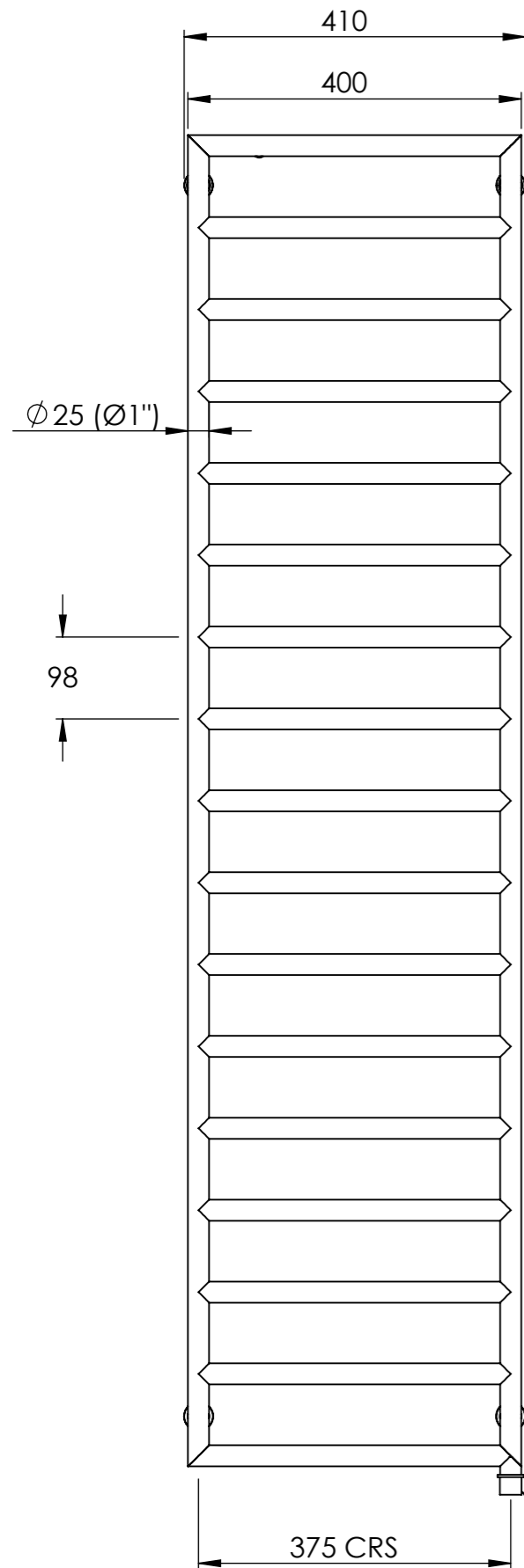

RIGHT HAND SIDE
ELEMENT POSITION
& CABLE EXIT

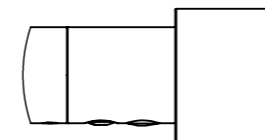
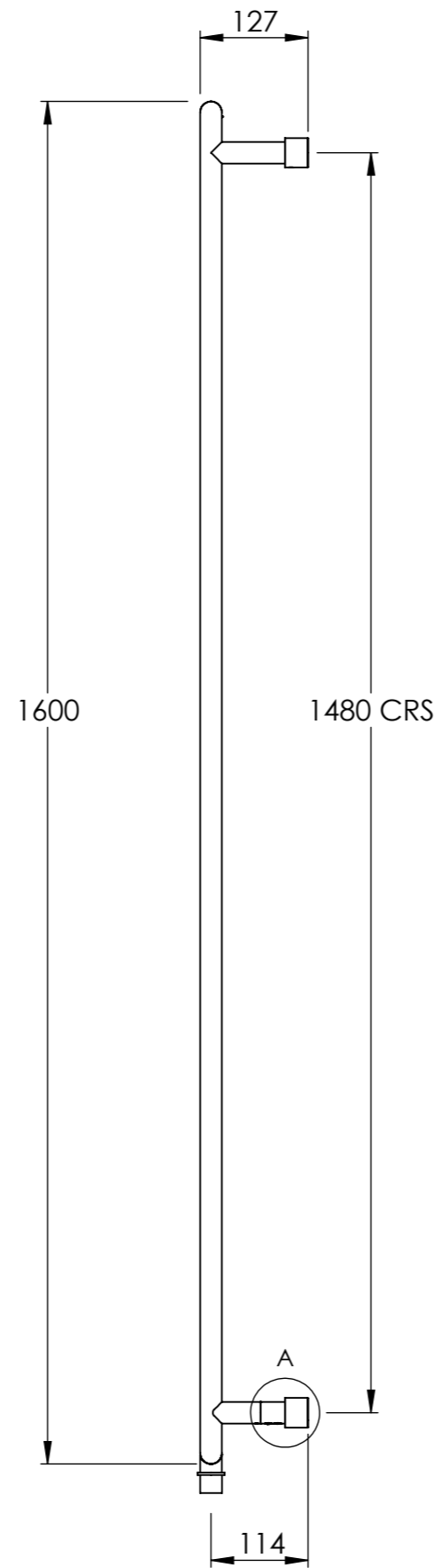

DETAIL A
SCALE 1 : 2

PATENTED INTEGRATED VALVES
INSTALLED ON LOWER WALL RETURNS

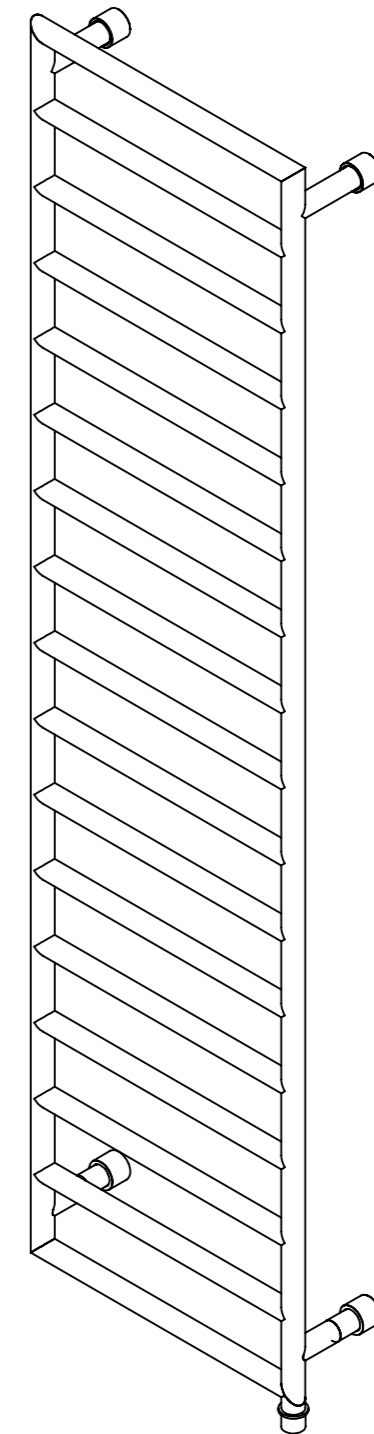

REFER TO PAGE 2 FOR ELECTRICAL CONNECTION AND CABLE COVER SPECIFICATION

DO NOT SCALE DRAWING ALL DIMENSIONS ARE IN MILLIMETERS AND MAY VARY ± 5mm AS THEY ARE HANDMADE, HAND SOLDERED AND POLISHED

WE THEREFORE RECOMMEND THAT ANY INSTALLATION WORK BE CARRIED OUT UPON RECEIPT OF RAIL.

BTU/HR AT DELTA 60:	1580	TEST PRESSURE:	6 BAR
ELECTRICAL ELEMENT WATTAGE:	200	MAX WORKING TEMPERATURE:	100°C
		CONNECTIONS	15mm COMPRESSION
HEAT OUTPUT DETERMINED IN ACCORDANCE WITH EN 442			
BARD & BRAZIER LIMITED MARSTON ROAD WOLVERHAMPTON WEST MIDLANDS WV2 4LX UK		T: +44 (0) 121 270 2222 E: INFO@BARDBRAZIER.CO.UK WWW.BARDBRAZIER.CO.UK	
TITLE: D-RAIL 17 BAR TOWEL WARMER 1600 x 400mm - DUAL FUEL			
BARD & BRAZIER RAILS ARE MADE IN ENGLAND FROM HIGH QUALITY BRASS AND CAN BE USED ON OPEN OR CLOSED CIRCUITS		SCALE:	DATE:
		1:8	16/04/2018
BARD & BRAZIER		PRODUCT CODE:	
		DRW160-40DF	



BARD & BRAZIER

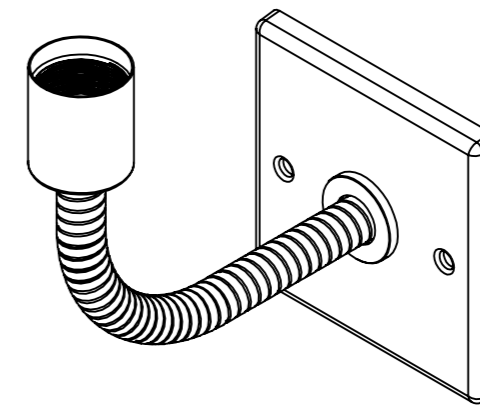
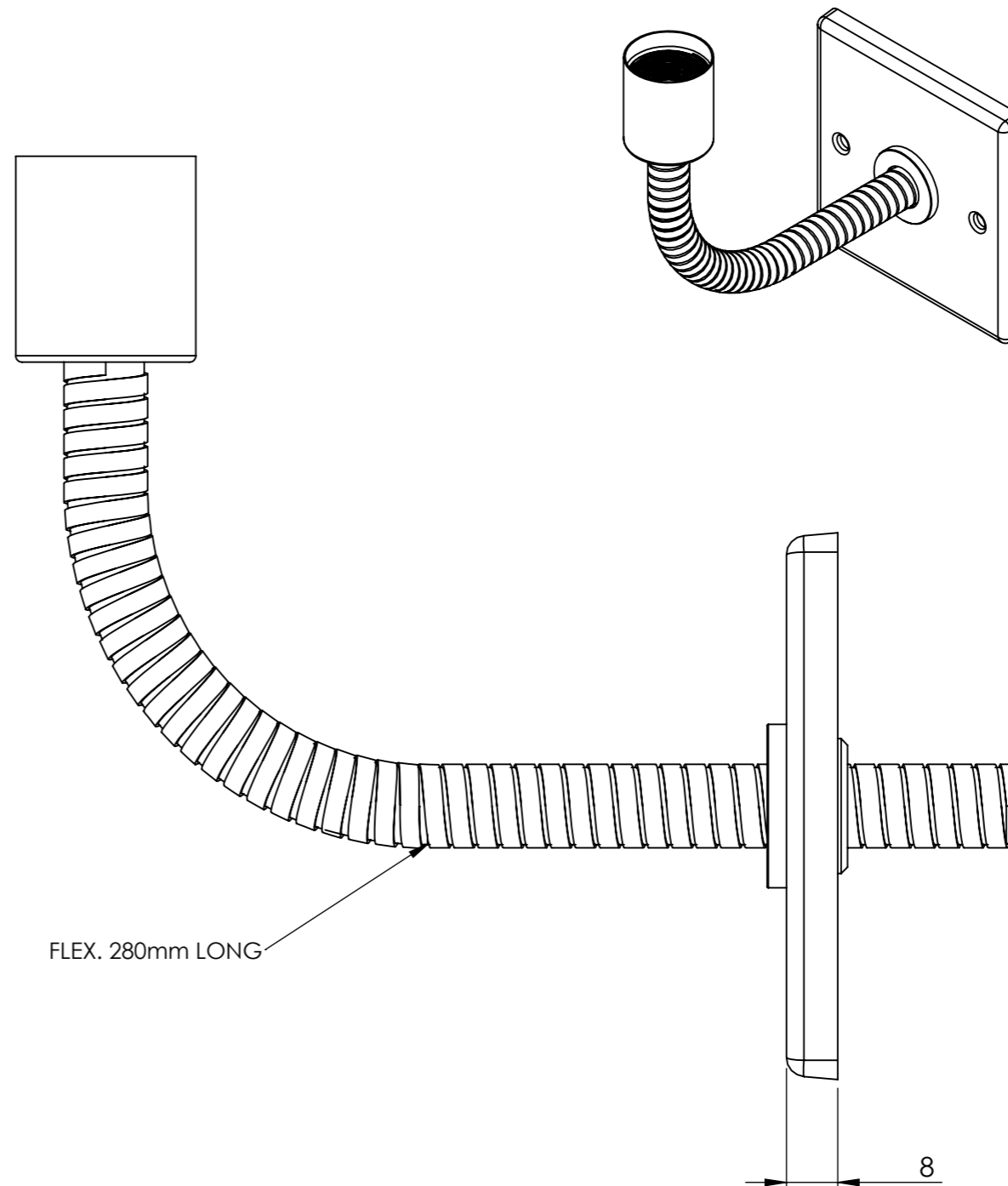
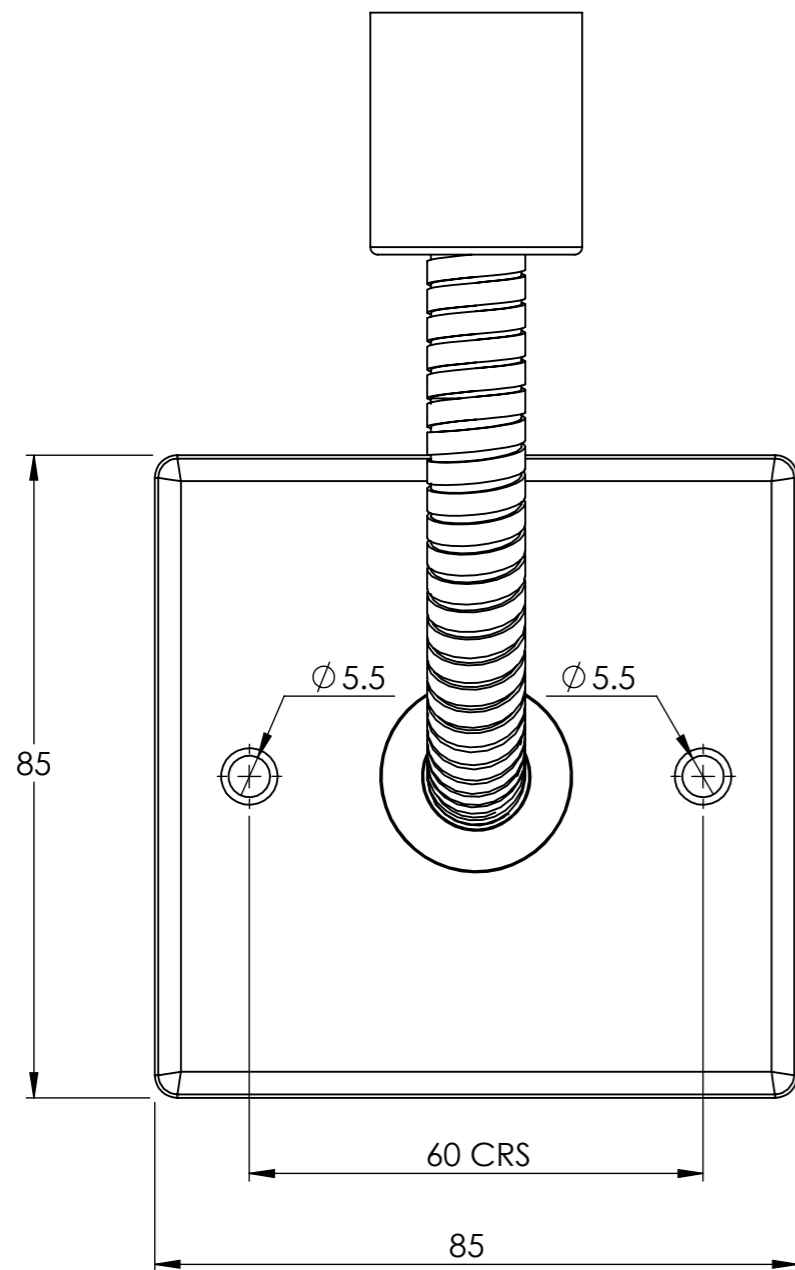

FINISH TO MATCH WITH CHOSEN RAIL

DO NOT SCALE DRAWING ALL DIMENSIONS ARE IN MILLIMETERS AND MAY VARY ± 5mm AS THEY ARE HANDMADE, HAND SOLDERED AND POLISHED

WE THEREFORE RECOMMEND THAT ANY INSTALLATION WORK BE CARRIED OUT UPON RECEIPT OF RAIL.

BARD & BRAZIER LIMITED T: +44 (0) 121 270 2222
 MARSTON ROAD E: INFO@BARDBRAZIER.CO.UK
 WOLVERHAMPTON
 WEST MIDLANDS WWW.BARDBRAZIER.CO.UK
 WV2 4LX
 UK

BARD & BRAZIER RAILS ARE MADE IN ENGLAND FROM HIGH QUALITY BRASS

TITLE:
ELECTRICAL KIT ASSEMBLY



SCALE: 1:1 DATE: 07/08/2018
 PRODUCT CODE: E201



BARD & BRAZIER

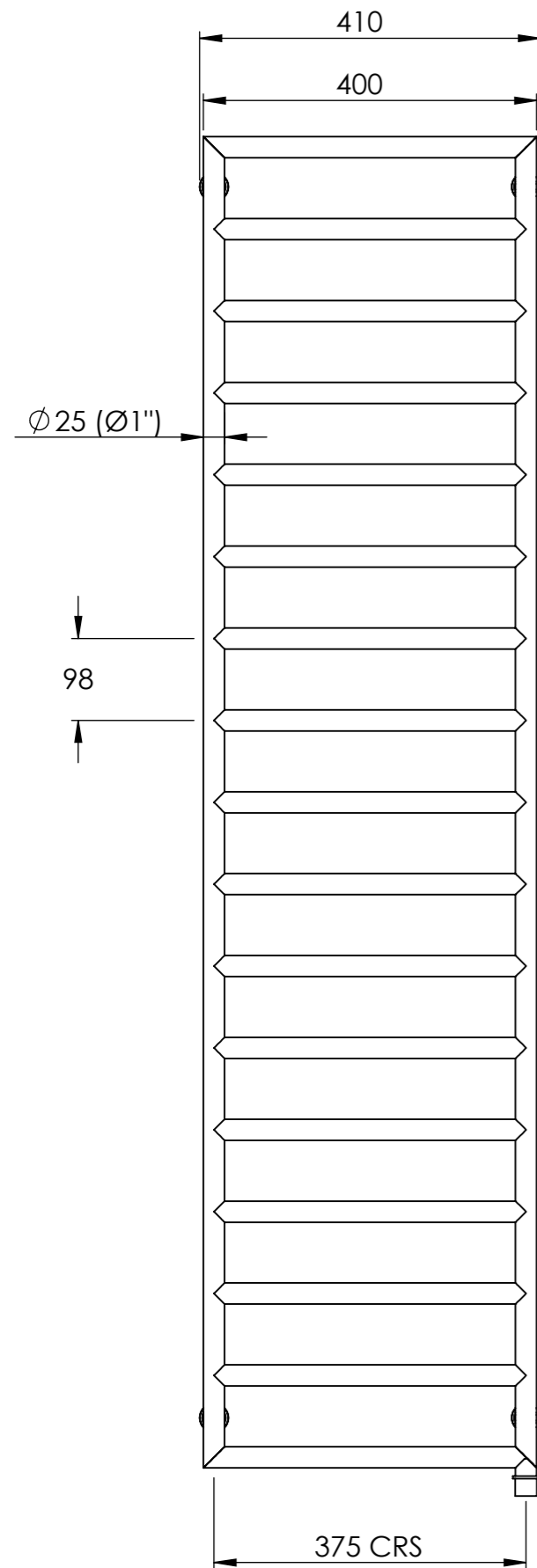

RIGHT HAND SIDE
ELEMENT POSITION
& CABLE EXIT

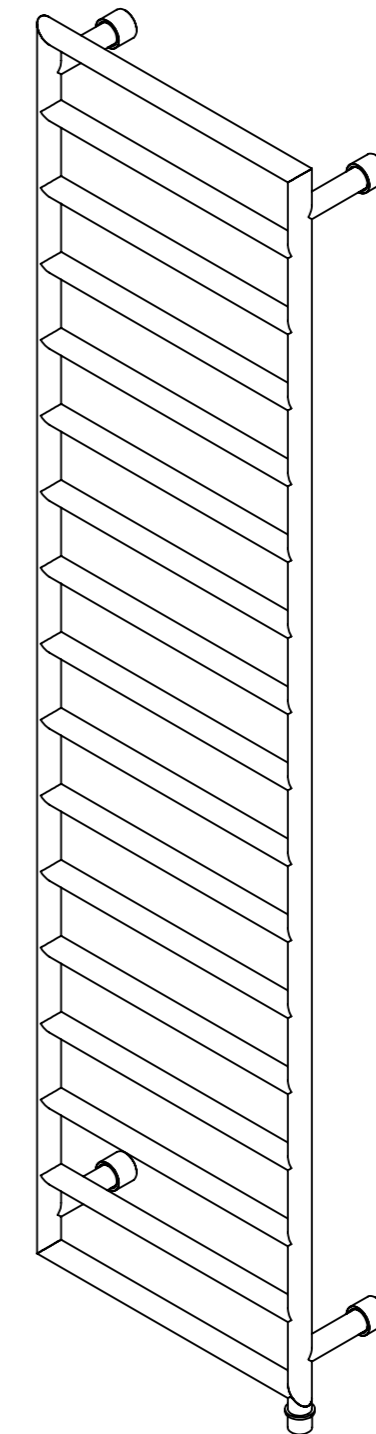
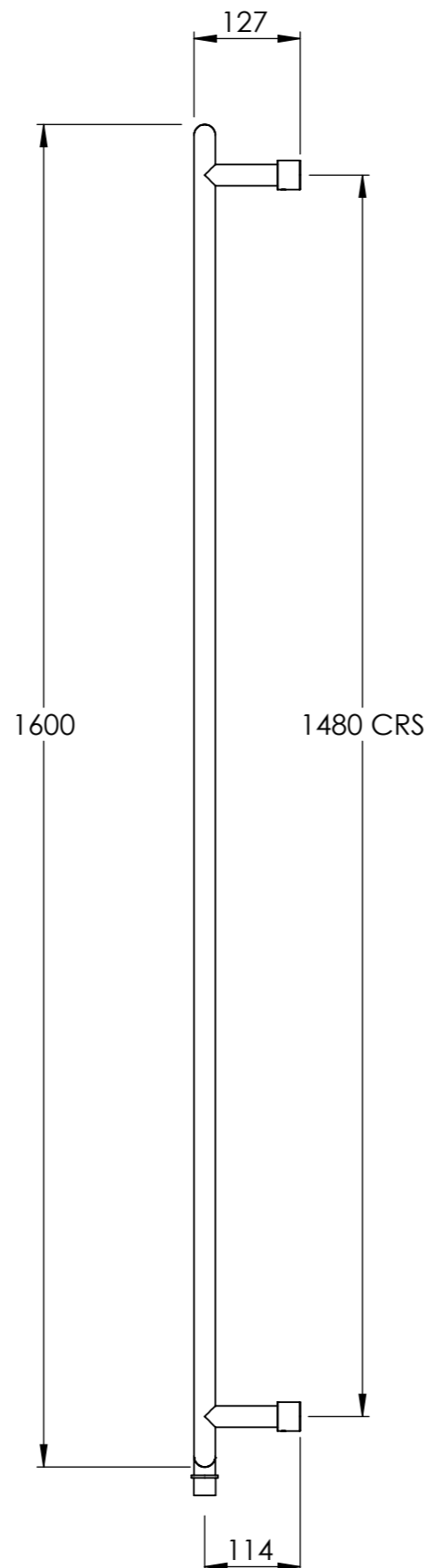

REFER TO PAGE 2 FOR ELECTRICAL CONNECTION AND COVER PLATE SPECIFICATION

DO NOT SCALE DRAWING ALL DIMENSIONS ARE IN MILLIMETERS AND MAY VARY ± 5mm AS THEY ARE HANDMADE, HAND SOLDERED AND POLISHED

WE THEREFORE RECOMMEND THAT ANY INSTALLATION WORK BE CARRIED OUT UPON RECEIPT OF RAIL.

BTU/HR AT DELTA 60:	1580	TEST PRESSURE:	6 BAR
ELECTRICAL ELEMENT WATTAGE:	200	MAX WORKING TEMPERATURE:	100°C
HEAT OUTPUT DETERMINED IN ACCORDANCE WITH EN 442			
BARD & BRAZIER LIMITED MARSTON ROAD WOLVERHAMPTON WEST MIDLANDS WV2 4LX UK		T: +44 (0) 121 270 2222 E: INFO@BARDBRAZIER.CO.UK WWW.BARDBRAZIER.CO.UK	
TITLE: D-RAIL 17 BAR TOWEL WARMER 1600 x 400mm - SEALED ELECTRIC			
 BARD & BRAZIER BARD & BRAZIER RAILS ARE MADE IN ENGLAND FROM HIGH QUALITY BRASS		SCALE:	DATE:
		1:8	16/04/2018
		PRODUCT CODE: DRW160-40SE	



BARD & BRAZIER

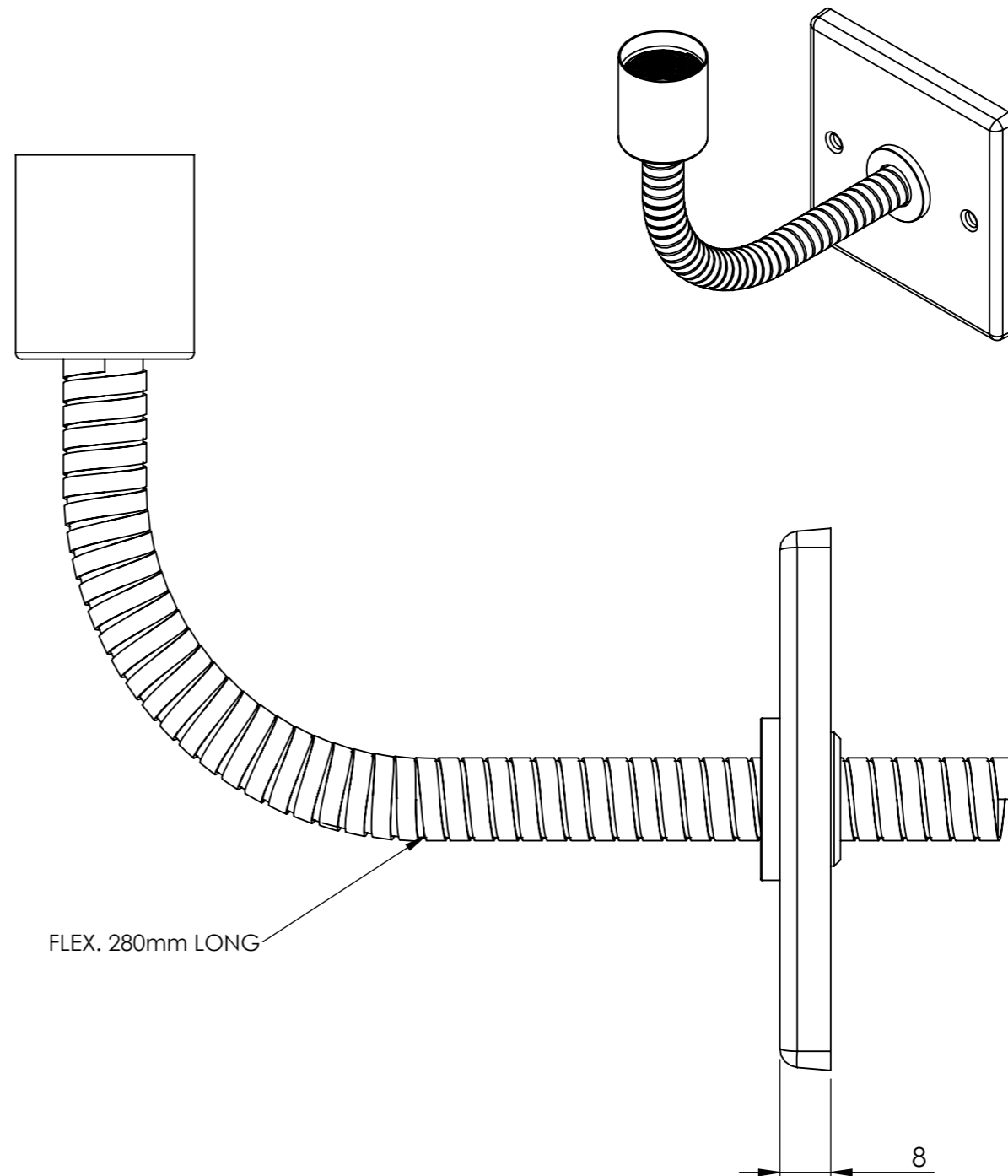
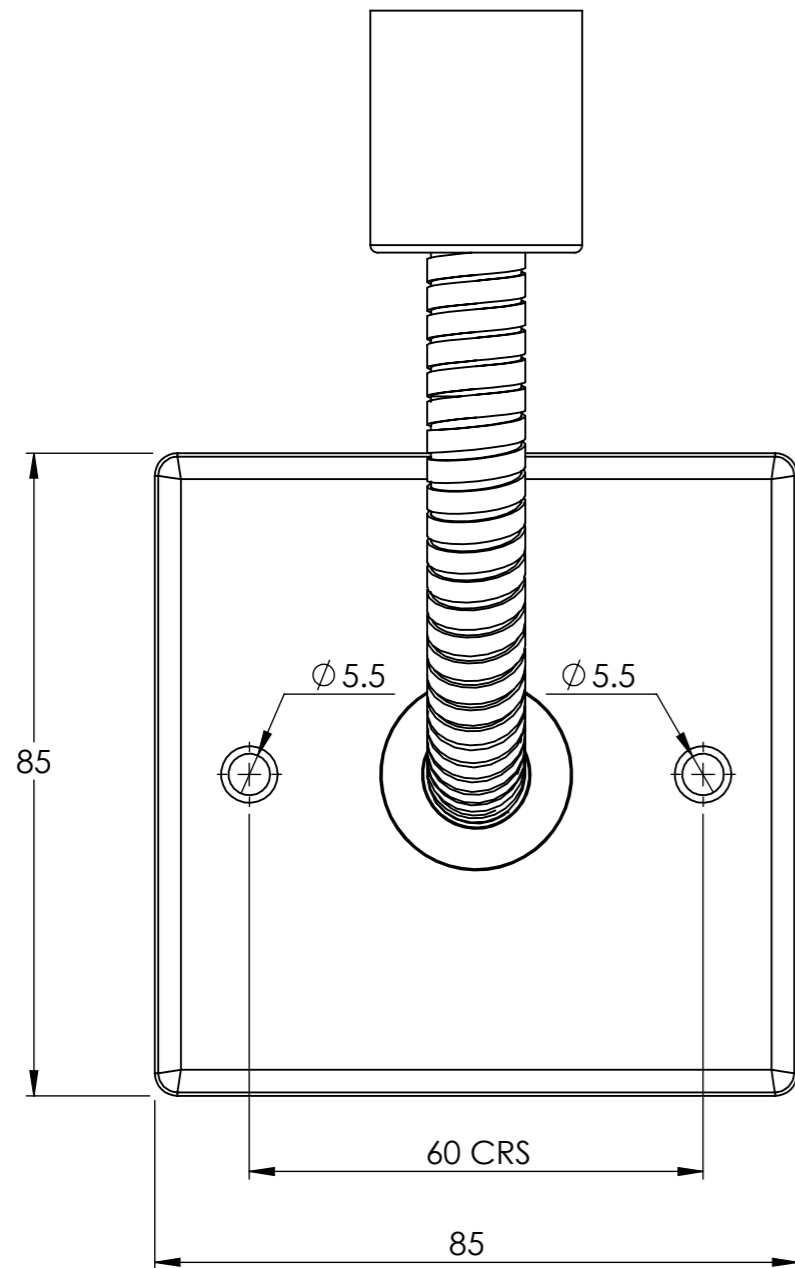

FINISH TO MATCH WITH CHOSEN RAIL

DO NOT SCALE DRAWING ALL DIMENSIONS ARE IN MILLIMETERS AND MAY VARY ± 5mm AS THEY ARE HANDMADE, HAND SOLDERED AND POLISHED

WE THEREFORE RECOMMEND THAT ANY INSTALLATION WORK BE CARRIED OUT UPON RECEIPT OF RAIL.

BARD & BRAZIER LIMITED T: +44 (0) 121 270 2222
 MARSTON ROAD E: INFO@BARDBRAZIER.CO.UK
 WOLVERHAMPTON
 WEST MIDLANDS WWW.BARDBRAZIER.CO.UK
 WV2 4LX
 UK

BARD & BRAZIER RAILS ARE MADE IN ENGLAND FROM HIGH QUALITY BRASS

TITLE:
ELECTRICAL KIT ASSEMBLY



SCALE: 1:1
DATE: 07/08/2018

PRODUCT CODE:
E201