

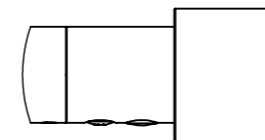

BARD & BRAZIER

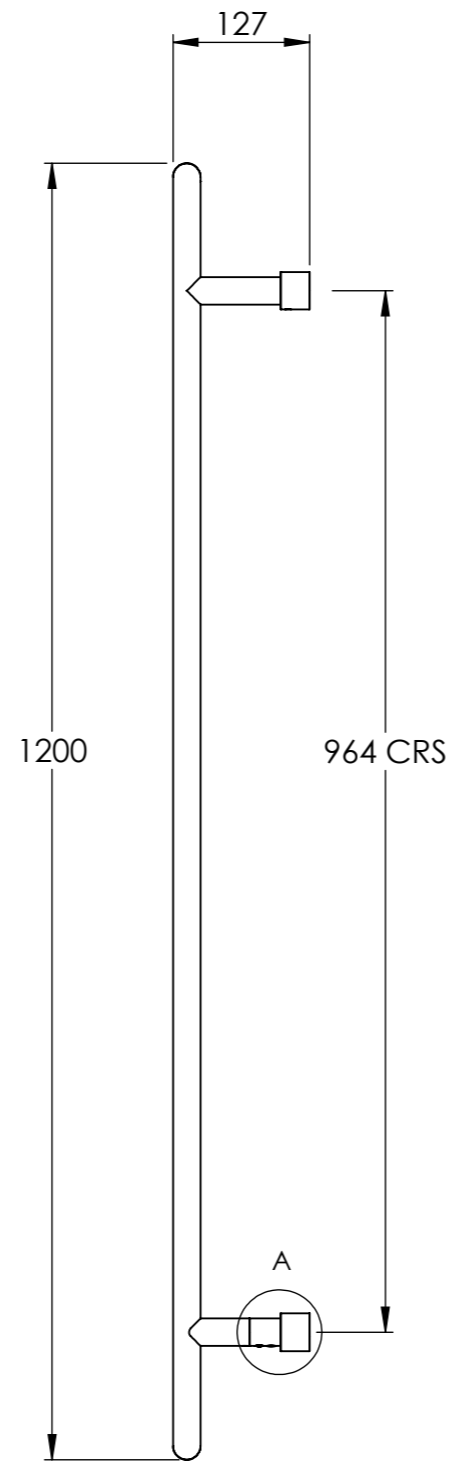
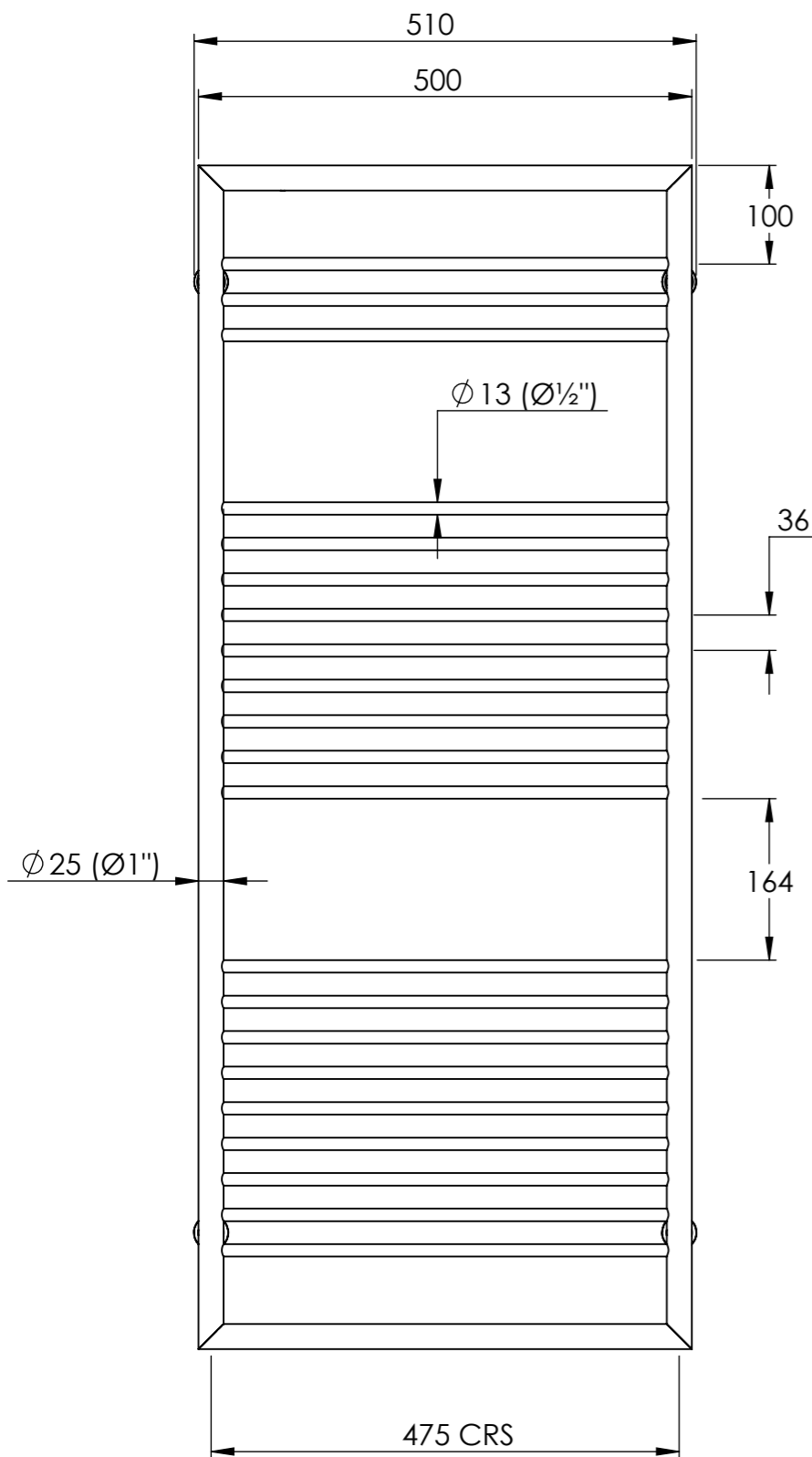

DETAIL A
SCALE 1 : 2

PATENTED INTEGRATED VALVES
INSTALLED ON LOWER WALL RETURNS

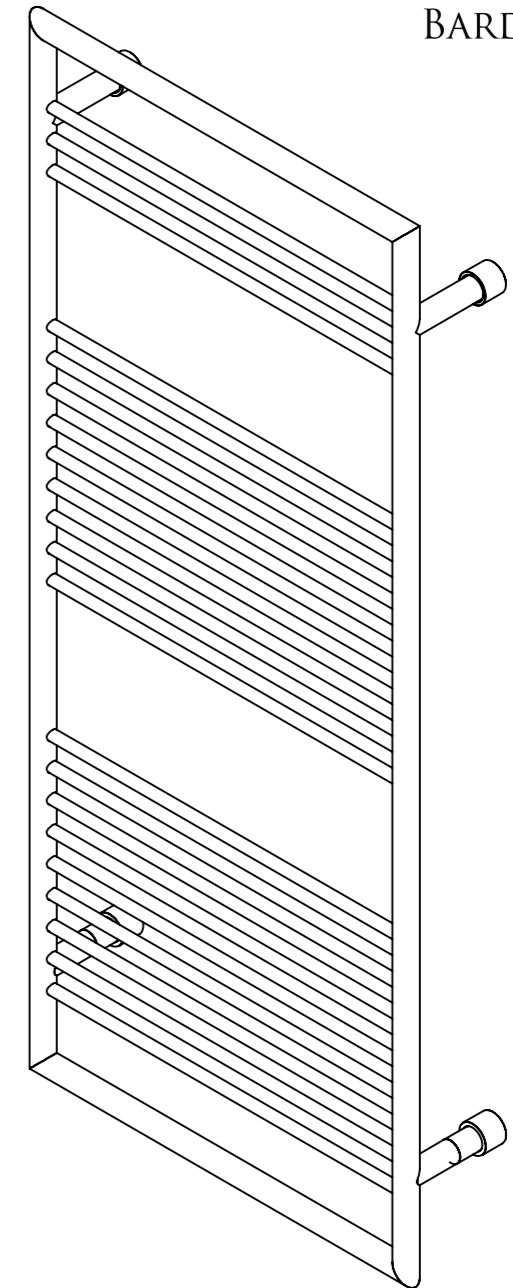

DO NOT SCALE DRAWING ALL DIMENSIONS ARE IN MILLIMETERS AND MAY VARY ± 5 mm AS THEY ARE HANDMADE, HAND SOLDERED AND POLISHED
WE THEREFORE RECOMMEND THAT ANY INSTALLATION WORK BE CARRIED OUT UPON RECEIPT OF RAIL.

BTU/HR AT DELTA 60:	1350	TEST PRESSURE:	6 BAR
CONNECTIONS:	15mm COMPRESSION	MAX WORKING PRESSURE:	3 BAR
		MAX WORKING TEMPERATURE:	100°C
HEAT OUTPUT DETERMINED IN ACCORDANCE WITH EN 442			
BARD & BRAZIER LIMITED MARSTON ROAD WOLVERHAMPTON WEST MIDLANDS WV2 4LX UK		T: +44 (0) 121 270 2222 E: INFO@BARDBRAZIER.CO.UK WWW.BARDBRAZIER.CO.UK	
TITLE: D-RAIL 3 SECTION - 23 BAR TOWEL WARMER 1200 x 500mm - HYDRONIC			
BARD & BRAZIER RAILS ARE MADE IN ENGLAND FROM HIGH QUALITY BRASS AND CAN BE USED ON OPEN OR CLOSED CIRCUITS		SCALE: 1:7	DATE: 20/05/2019
		PRODUCT CODE: DRW120-50	



BARD & BRAZIER

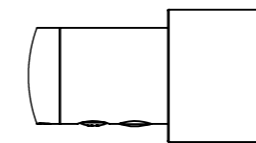
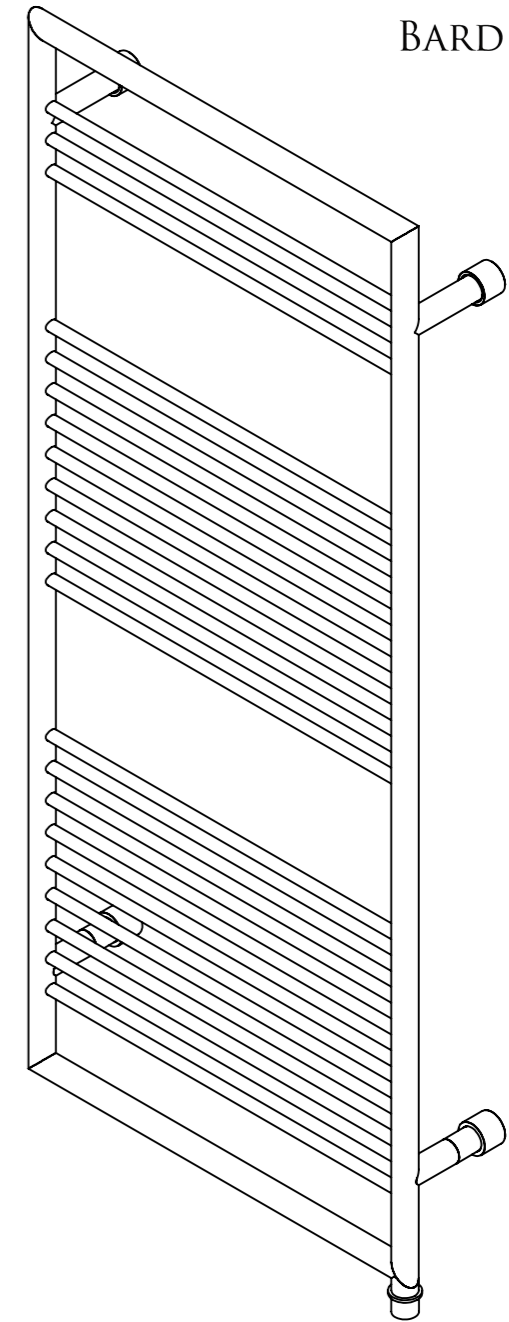
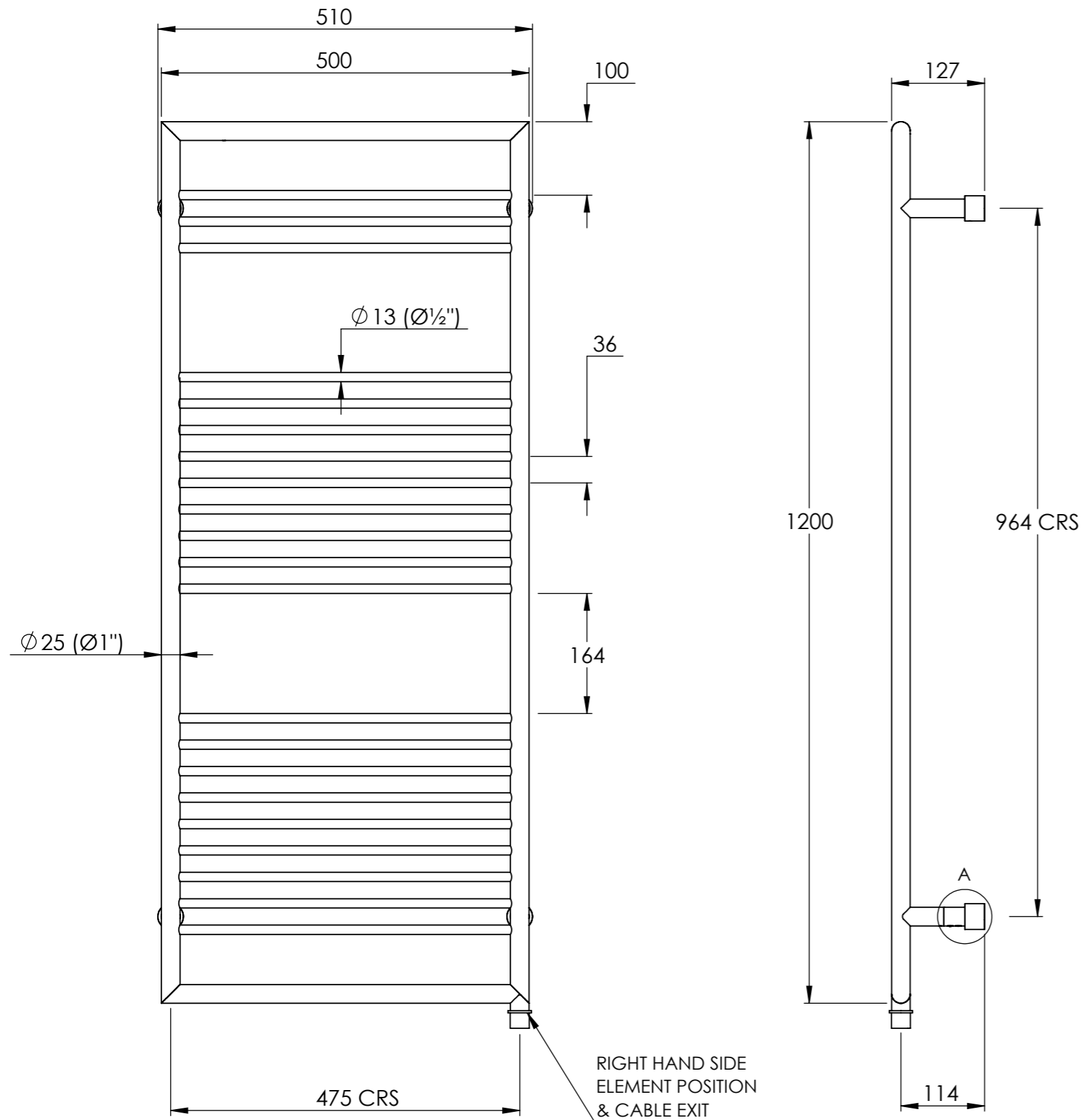

DETAIL A
SCALE 1 : 2

PATENTED INTEGRATED VALVES
INSTALLED ON LOWER WALL RETURNS

RIGHT HAND SIDE
ELEMENT POSITION
& CABLE EXIT

REFER TO PAGE 2 FOR ELECTRICAL CONNECTION AND CABLE COVER SPECIFICATION

DO NOT SCALE DRAWING ALL DIMENSIONS ARE IN MILLIMETERS AND MAY VARY ± 5mm AS THEY ARE HANDMADE, HAND SOLDERED AND POLISHED

WE THEREFORE RECOMMEND THAT ANY INSTALLATION WORK BE CARRIED OUT UPON RECEIPT OF RAIL.

BTU/HR AT DELTA 60:	1350	TEST PRESSURE:	6 BAR
ELECTRICAL ELEMENT WATTAGE:	150	MAX WORKING TEMPERATURE:	100°C
		CONNECTIONS	15mm COMPRESSION
HEAT OUTPUT DETERMINED IN ACCORDANCE WITH EN 442			

BARD & BRAZIER LIMITED
MARSTON ROAD
WOLVERHAMPTON
WEST MIDLANDS
WV2 4LX
UK

T: +44 (0) 121 270 2222
E: INFO@BARDBRAZIER.CO.UK
WWW.BARDBRAZIER.CO.UK

TITLE:
D-RAIL 3 SECTION - 23 BAR TOWEL WARMER
1200 x 500mm - DUAL FUEL

BARD & BRAZIER RAILS ARE MADE IN ENGLAND
FROM HIGH QUALITY BRASS AND CAN BE USED
ON OPEN OR CLOSED CIRCUITS



SCALE: 1:7
DATE: 20/05/2019

PRODUCT CODE:
DRW120-50DF



BARD & BRAZIER

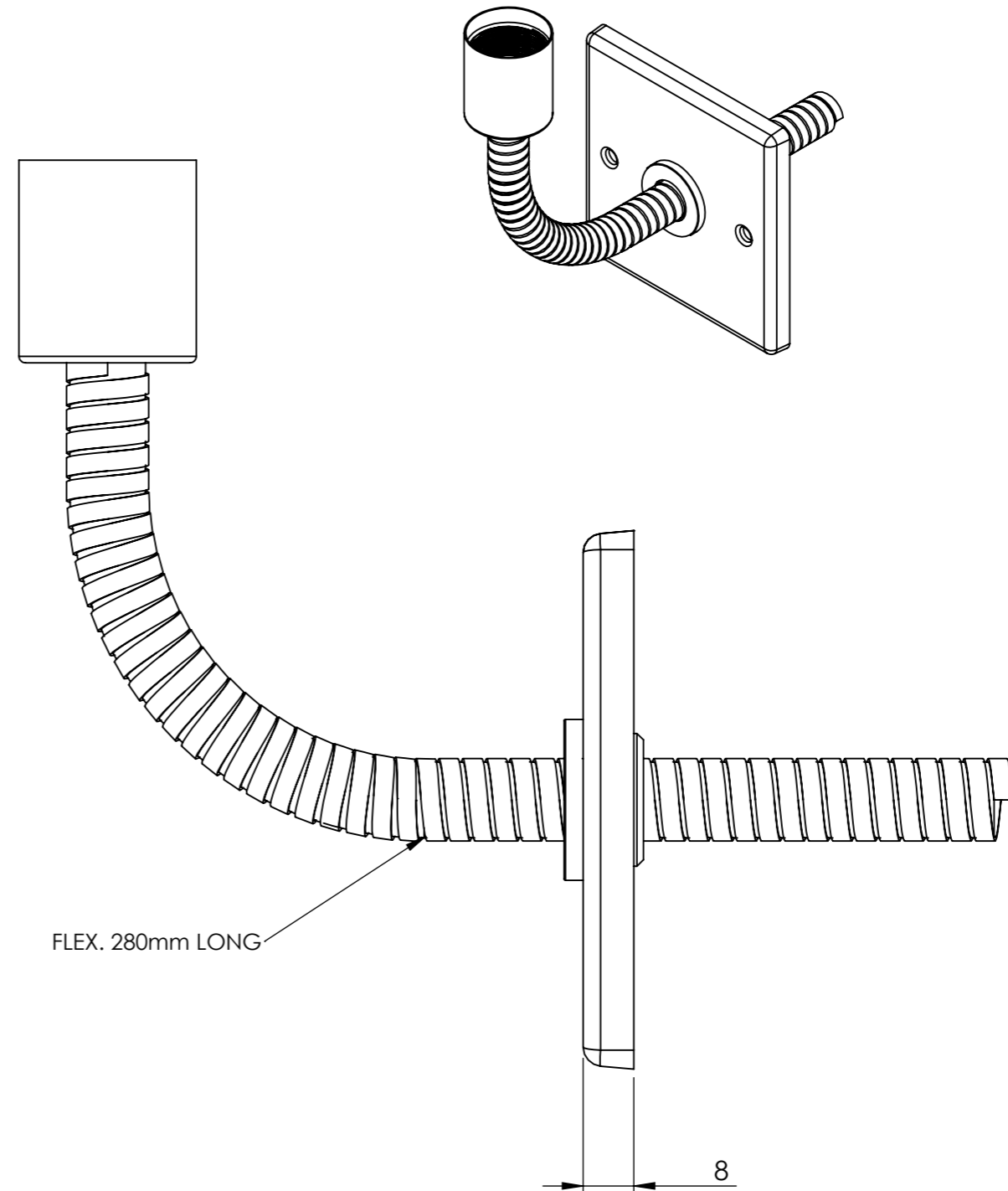
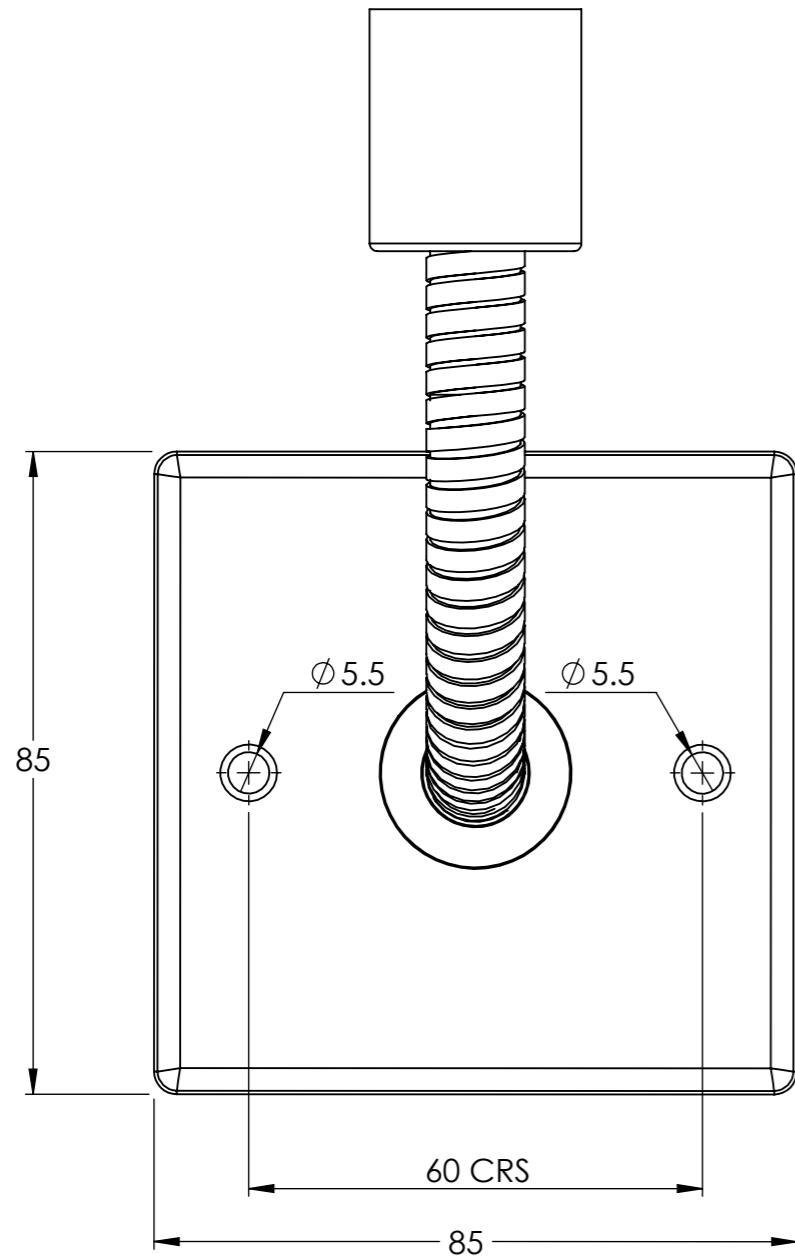

FINISH TO MATCH WITH CHOSEN RAIL

DO NOT SCALE DRAWING ALL DIMENSIONS ARE IN MILLIMETERS AND MAY VARY ± 5mm AS THEY ARE HANDMADE, HAND SOLDERED AND POLISHED
WE THEREFORE RECOMMEND THAT ANY INSTALLATION WORK BE CARRIED OUT UPON RECEIPT OF RAIL.

BARD & BRAZIER LIMITED T: +44 (0) 121 270 2222
MARSTON ROAD E: INFO@BARDBRAZIER.CO.UK
WOLVERHAMPTON
WEST MIDLANDS WWW.BARDBRAZIER.CO.UK
WV2 4LX
UK

BARD & BRAZIER RAILS ARE MADE IN ENGLAND
FROM HIGH QUALITY BRASS

TITLE:
ELECTRICAL KIT ASSEMBLY



SCALE: 1:1 DATE: 07/08/2018
PRODUCT CODE: E201



BARD & BRAZIER

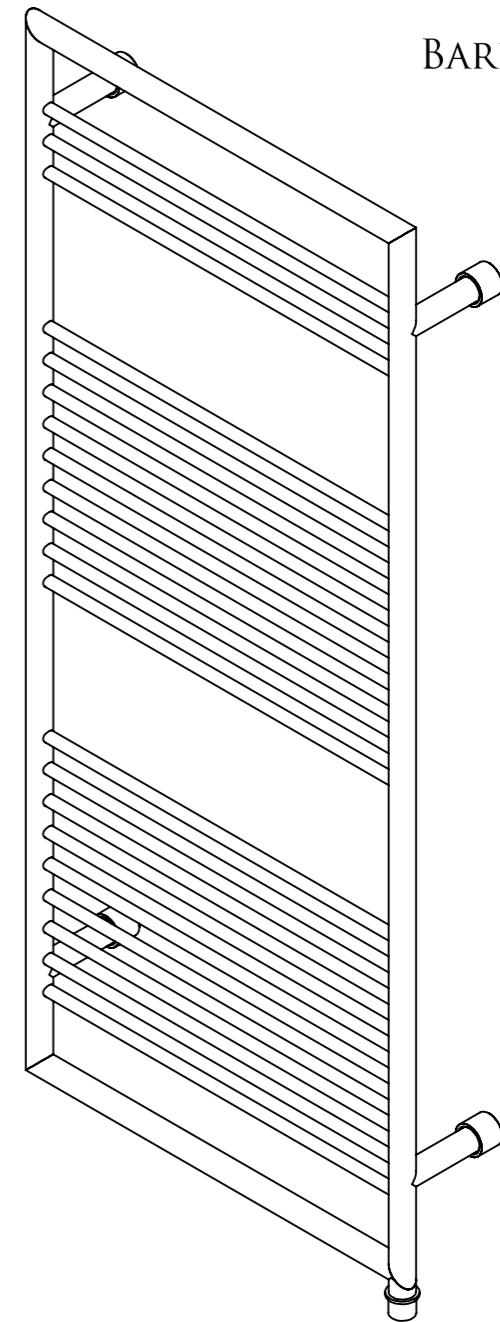
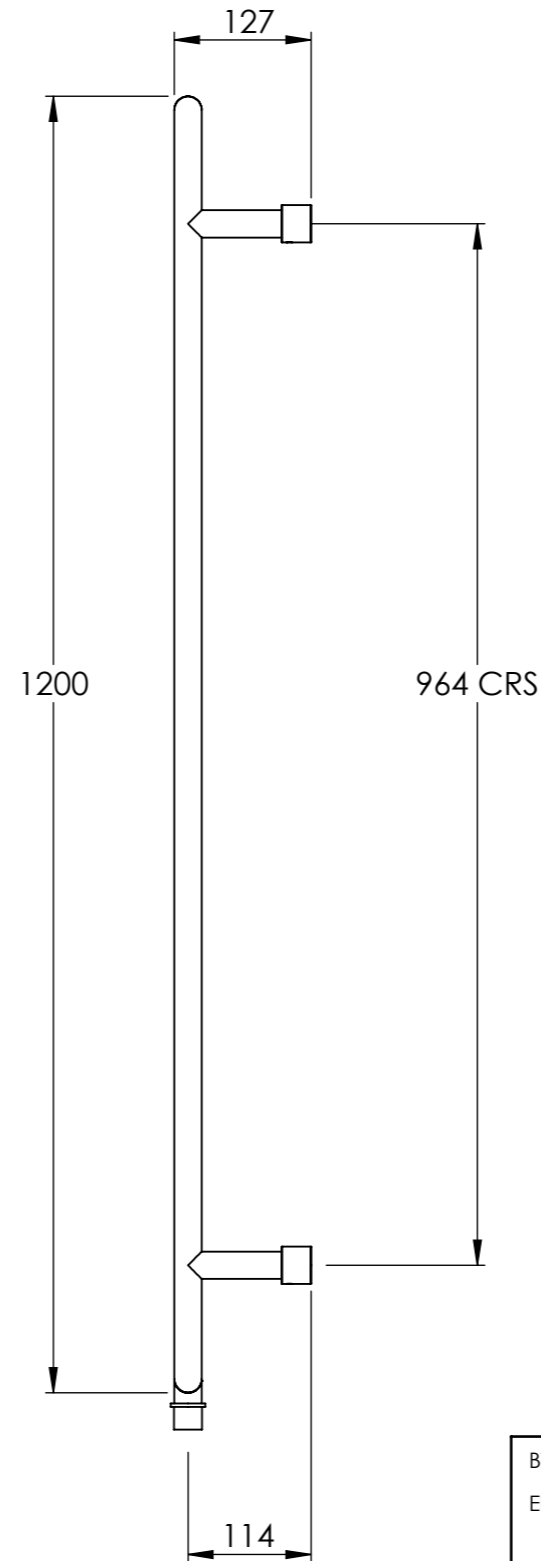
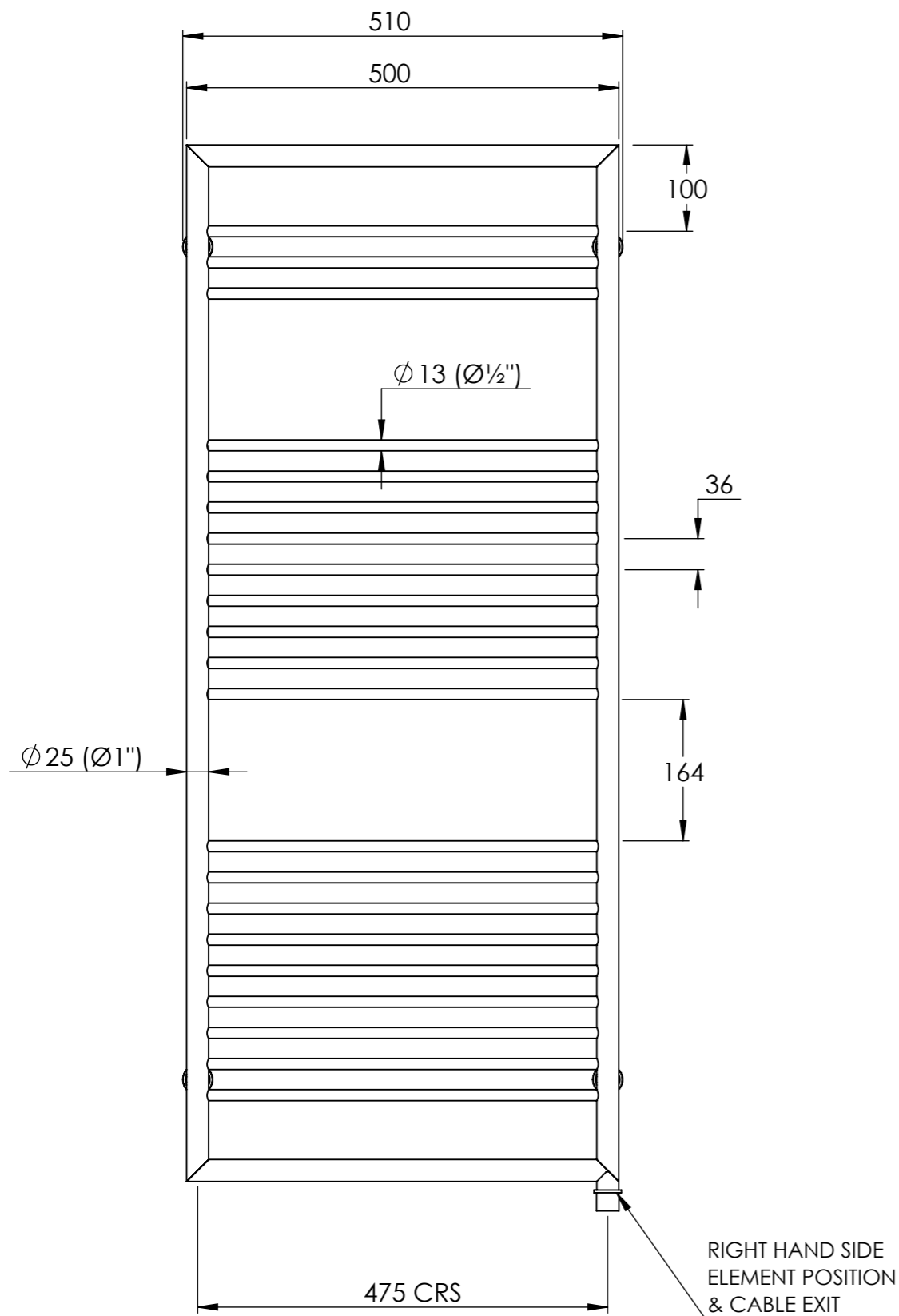

REFER TO PAGE 2 FOR ELECTRICAL CONNECTION AND COVER PLATE SPECIFICATION

DO NOT SCALE DRAWING ALL DIMENSIONS ARE IN MILLIMETERS AND MAY VARY ± 5mm AS THEY ARE HANDMADE, HAND SOLDERED AND POLISHED

WE THEREFORE RECOMMEND THAT ANY INSTALLATION WORK BE CARRIED OUT UPON RECEIPT OF RAIL.

BTU/HR AT DELTA 60:	1350	TEST PRESSURE:	6 BAR
ELECTRICAL ELEMENT WATTAGE:	150	MAX WORKING TEMPERATURE:	100°C
HEAT OUTPUT DETERMINED IN ACCORDANCE WITH EN 442			
BARD & BRAZIER LIMITED MARSTON ROAD WOLVERHAMPTON WEST MIDLANDS WV2 4LX UK		T: +44 (0) 121 270 2222 E: INFO@BARDBRAZIER.CO.UK WWW.BARDBRAZIER.CO.UK	
TITLE: D-RAIL 3 SECTION - 23 BAR TOWEL WARMER 1200 x 500mm - SEALED ELECTRIC			
 BARD & BRAZIER BARD & BRAZIER RAILS ARE MADE IN ENGLAND FROM HIGH QUALITY BRASS		SCALE:	DATE:
		1:7	20/05/2019
		PRODUCT CODE: DRW120-50SE	



BARD & BRAZIER

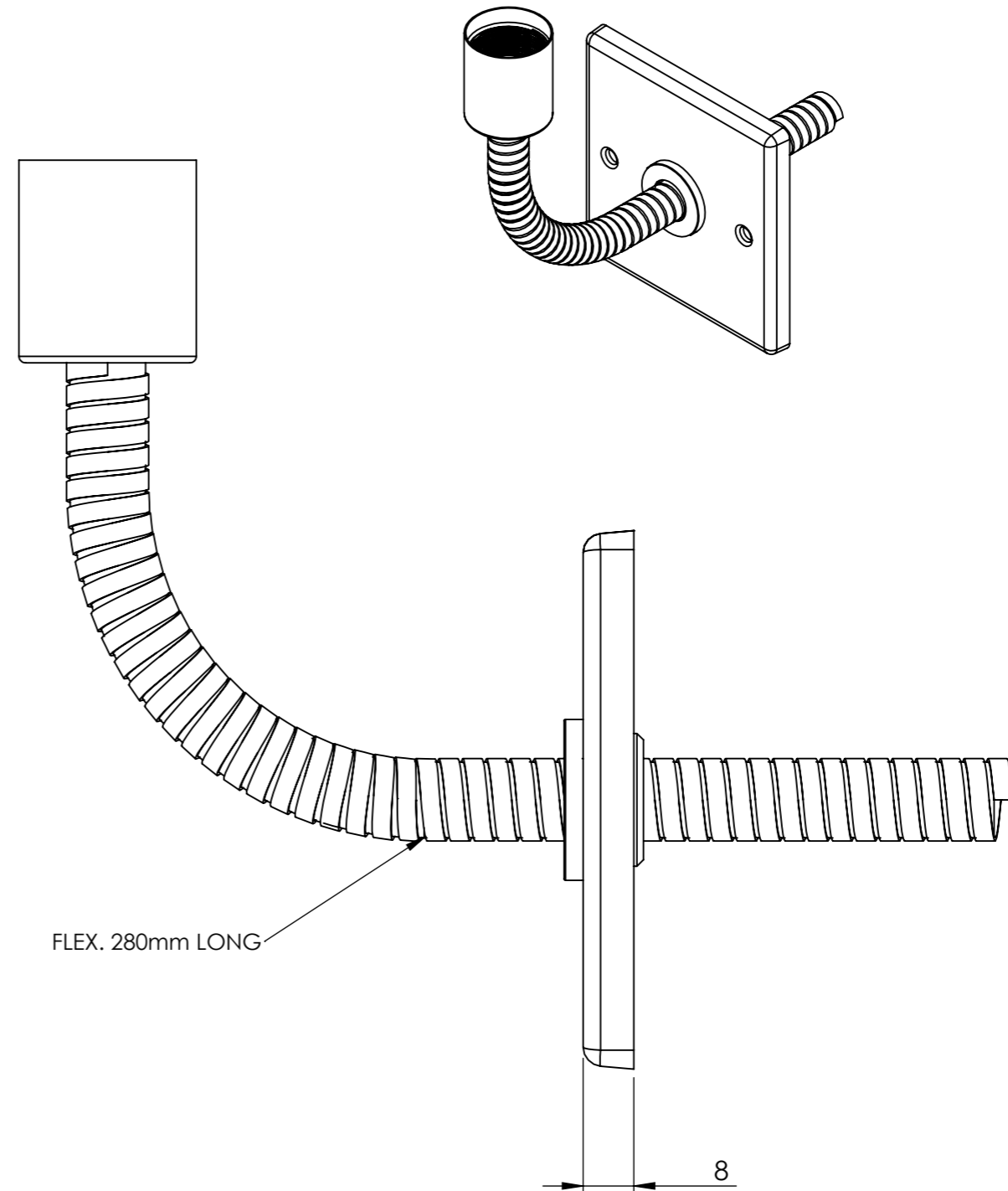
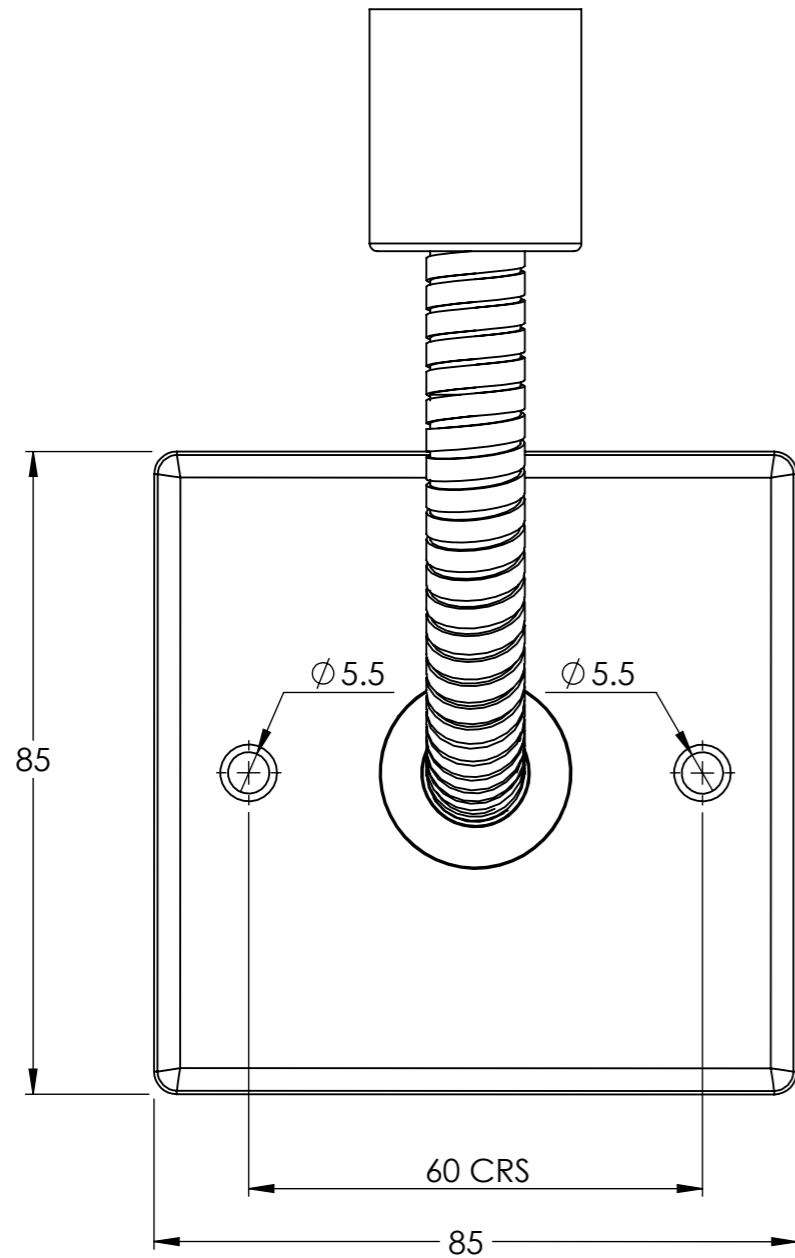

FINISH TO MATCH WITH CHOSEN RAIL

DO NOT SCALE DRAWING ALL DIMENSIONS ARE IN MILLIMETERS AND MAY VARY ± 5mm AS THEY ARE HANDMADE, HAND SOLDERED AND POLISHED
WE THEREFORE RECOMMEND THAT ANY INSTALLATION WORK BE CARRIED OUT UPON RECEIPT OF RAIL.

BARD & BRAZIER LIMITED T: +44 (0) 121 270 2222
MARSTON ROAD E: INFO@BARDBRAZIER.CO.UK
WOLVERHAMPTON
WEST MIDLANDS WWW.BARDBRAZIER.CO.UK
WV2 4LX
UK

BARD & BRAZIER RAILS ARE MADE IN ENGLAND
FROM HIGH QUALITY BRASS

TITLE:
ELECTRICAL KIT ASSEMBLY



SCALE: 1:1 DATE: 07/08/2018
PRODUCT CODE: E201