

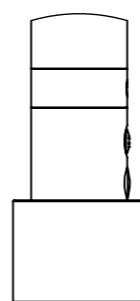

BARD & BRAZIER

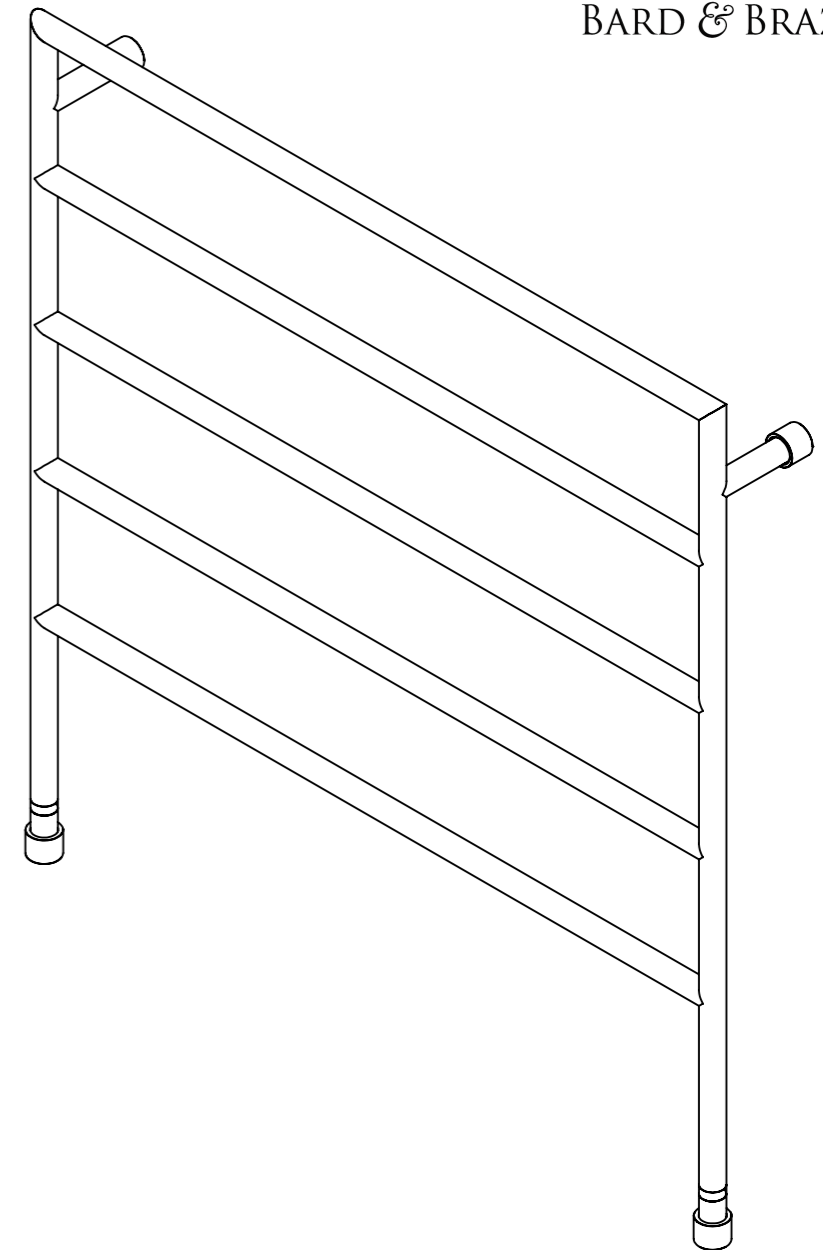
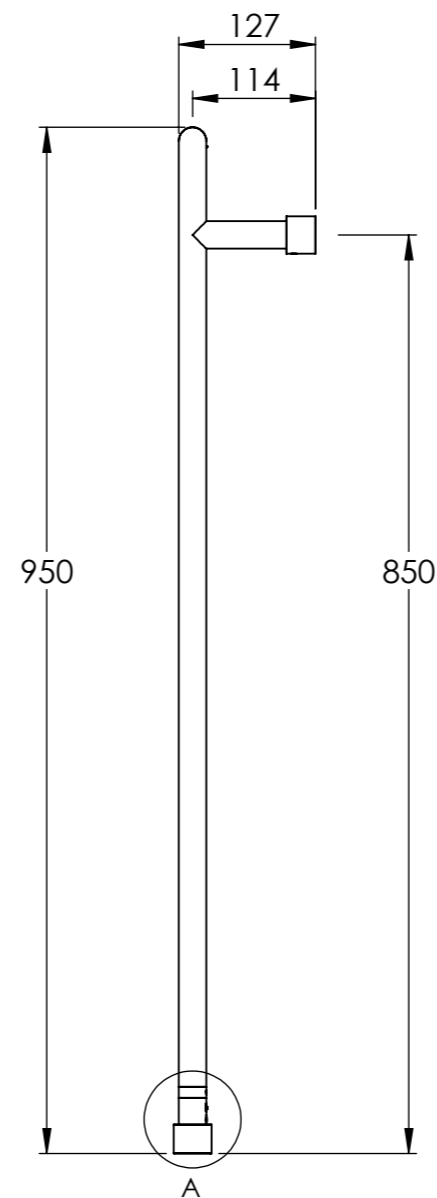
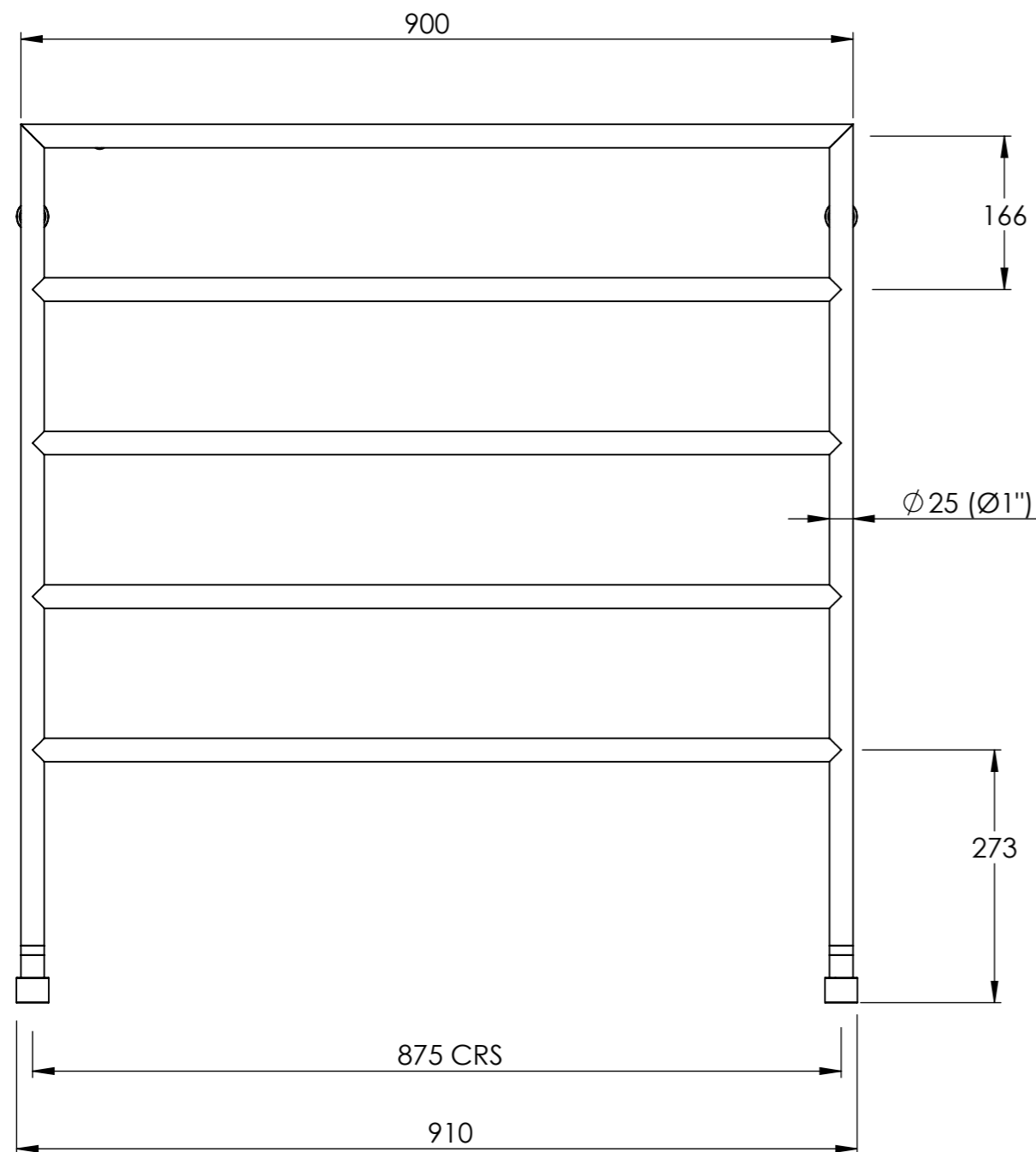

DETAIL A  
SCALE 1 : 2

PATENTED INTEGRATED VALVES  
INSTALLED ON FLOOR FIXTURES

DO NOT SCALE DRAWING ALL DIMENSIONS ARE IN MILLIMETERS AND MAY VARY ± 5mm AS THEY ARE HANDMADE, HAND SOLDERED AND POLISHED  
WE THEREFORE RECOMMEND THAT ANY INSTALLATION WORK BE CARRIED OUT UPON RECEIPT OF RAIL.

BTU/HR AT DELTA 60:	1040	TEST PRESSURE:	6 BAR
CONNECTIONS:	15mm COMPRESSION	MAX WORKING PRESSURE:	3 BAR
		MAX WORKING TEMPERATURE:	100°C
HEAT OUTPUT DETERMINED IN ACCORDANCE WITH EN 442			
BARD & BRAZIER LIMITED MARSTON ROAD WOLVERHAMPTON WEST MIDLANDS WV2 4LX UK		T: +44 (0) 121 270 2222 E: INFO@BARDBRAZIER.CO.UK WWW.BARDBRAZIER.CO.UK	
TITLE: D-RAIL 5 BAR TOWEL WARMER 950 x 900mm - HYDRONIC			
BARD & BRAZIER RAILS ARE MADE IN ENGLAND FROM HIGH QUALITY BRASS AND CAN BE USED ON OPEN OR CLOSED CIRCUITS		SCALE:	DATE:
		1:7	16/04/2018
BARD & BRAZIER		PRODUCT CODE:	
		DRF95-90	



BARD & BRAZIER

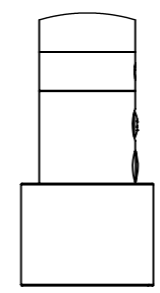
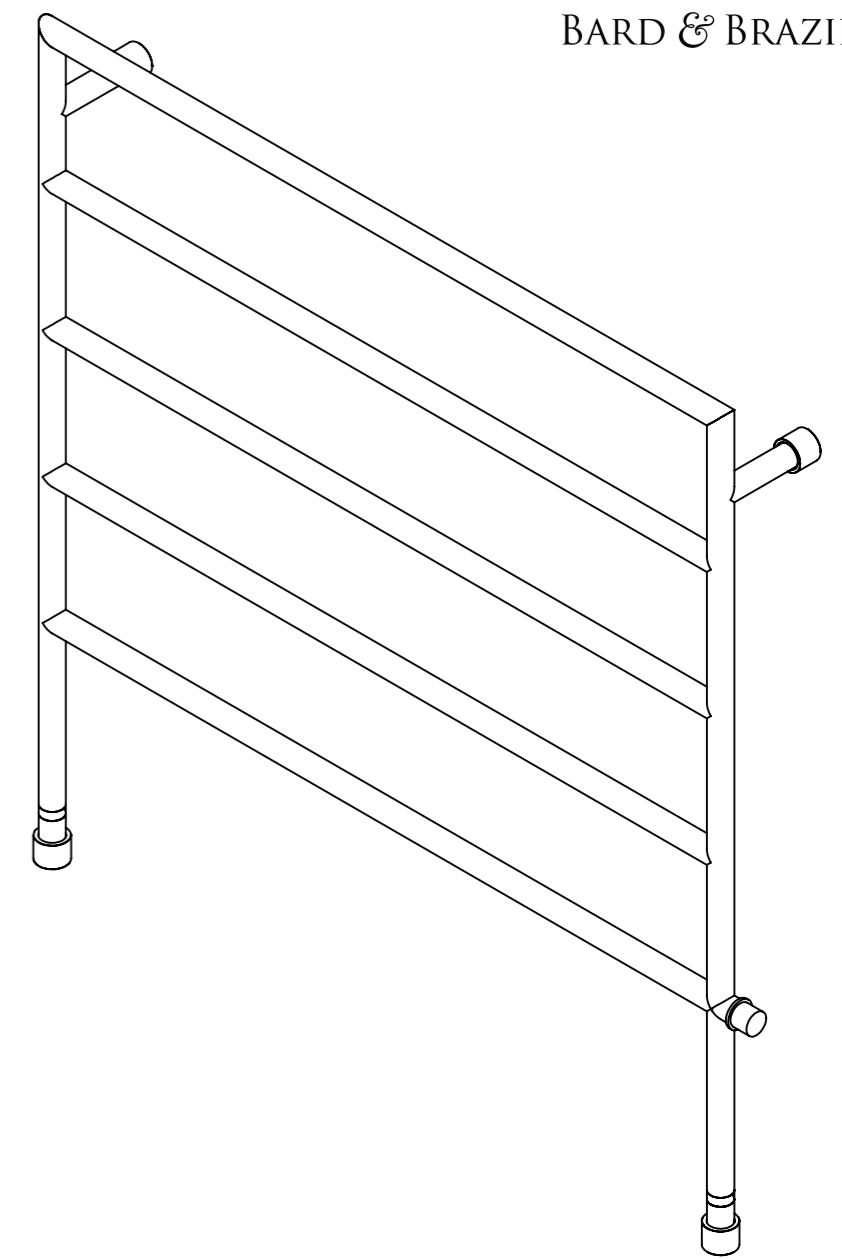
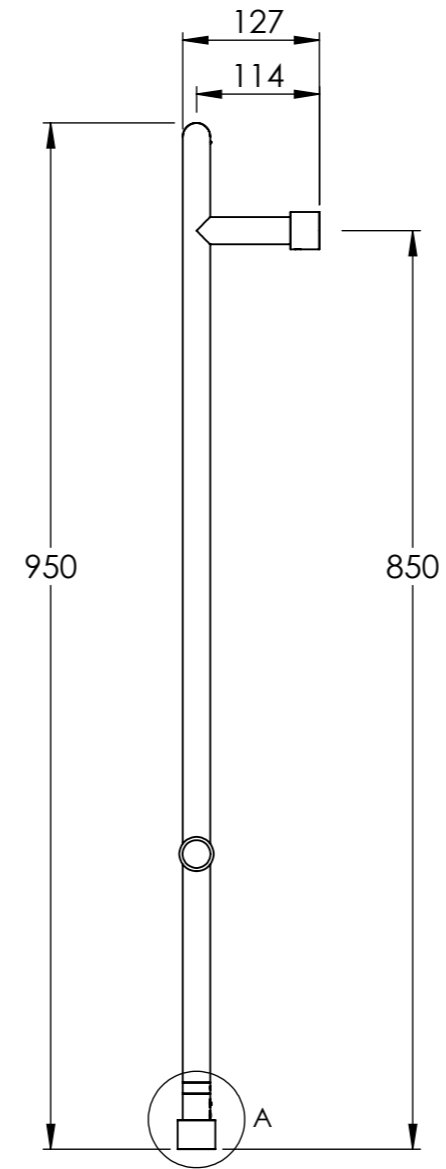
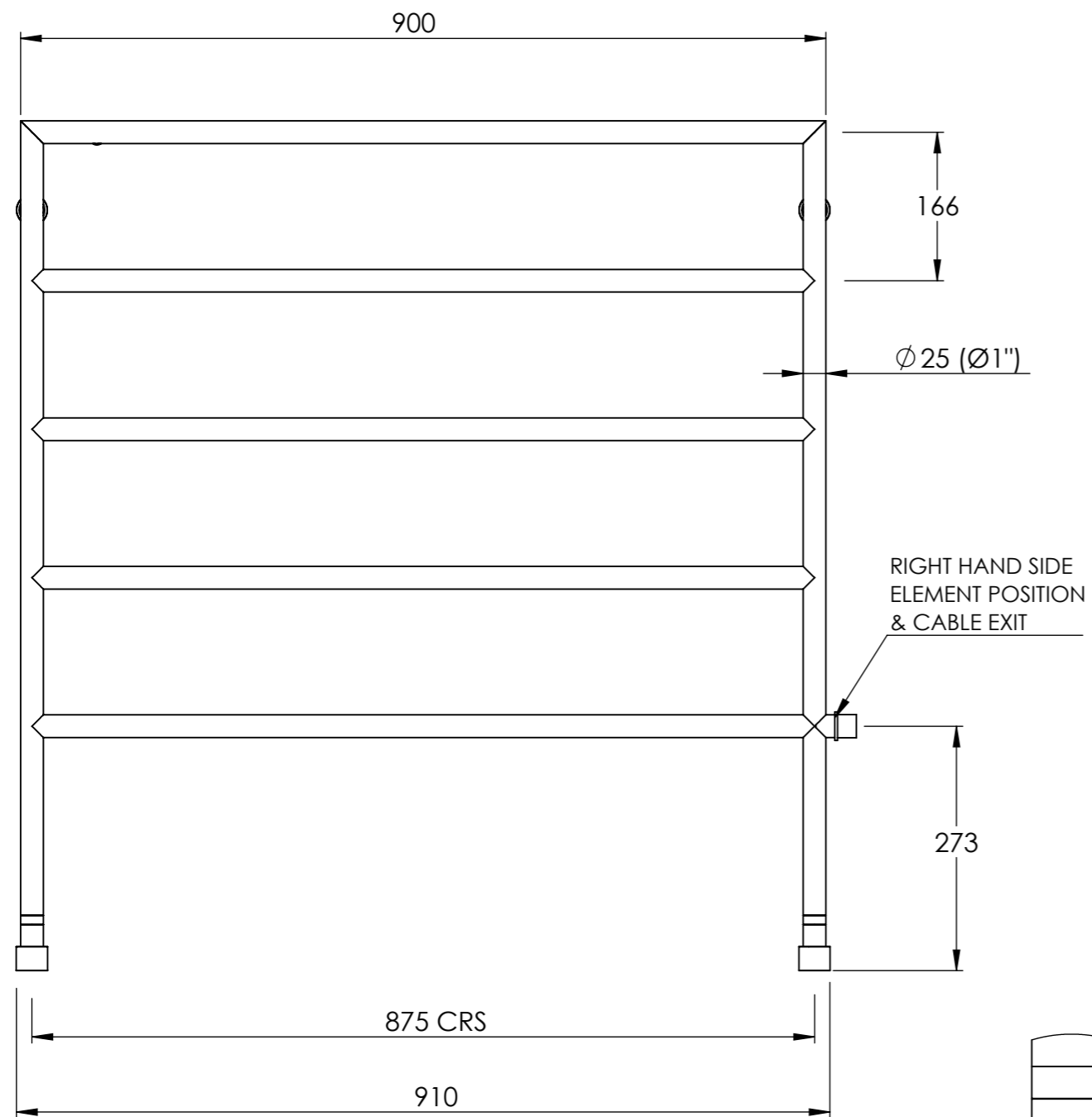

DETAIL A  
SCALE 1 : 2

PATENTED INTEGRATED VALVES  
INSTALLED ON FLOOR FIXTURES

REFER TO PAGE 2 FOR ELECTRICAL CONNECTION AND CABLE COVER SPECIFICATION

DO NOT SCALE DRAWING ALL DIMENSIONS ARE IN MILLIMETERS AND MAY VARY ± 5mm AS THEY ARE HANDMADE, HAND SOLDERED AND POLISHED

WE THEREFORE RECOMMEND THAT ANY INSTALLATION WORK BE CARRIED OUT UPON RECEIPT OF RAIL.

BTU/HR AT DELTA 60:	1040	TEST PRESSURE:	6 BAR
ELECTRICAL ELEMENT WATTAGE:	100	MAX WORKING TEMPERATURE:	100°C
		CONNECTIONS	15mm COMPRESSION
HEAT OUTPUT DETERMINED IN ACCORDANCE WITH EN 442			
BARD & BRAZIER LIMITED MARSTON ROAD WOLVERHAMPTON WEST MIDLANDS WV2 4LX UK		T: +44 (0) 121 270 2222 E: INFO@BARDBRAZIER.CO.UK WWW.BARDBRAZIER.CO.UK	
TITLE: D-RAIL 5 BAR TOWEL WARMER 950 x 900mm - DUAL FUEL			
BARD & BRAZIER		SCALE:	DATE:
		1:7	16/04/2018
		PRODUCT CODE: DRF95-90DF	

BARD & BRAZIER RAILS ARE MADE IN ENGLAND FROM HIGH QUALITY BRASS AND CAN BE USED ON OPEN OR CLOSED CIRCUITS



BARD & BRAZIER

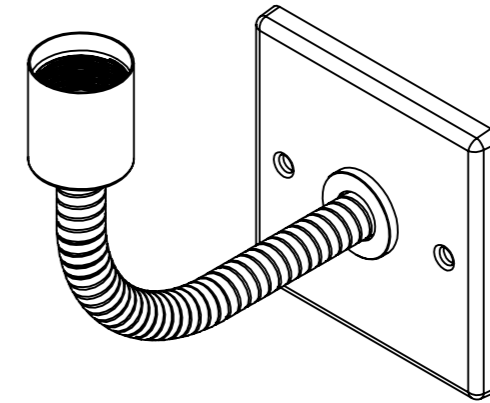
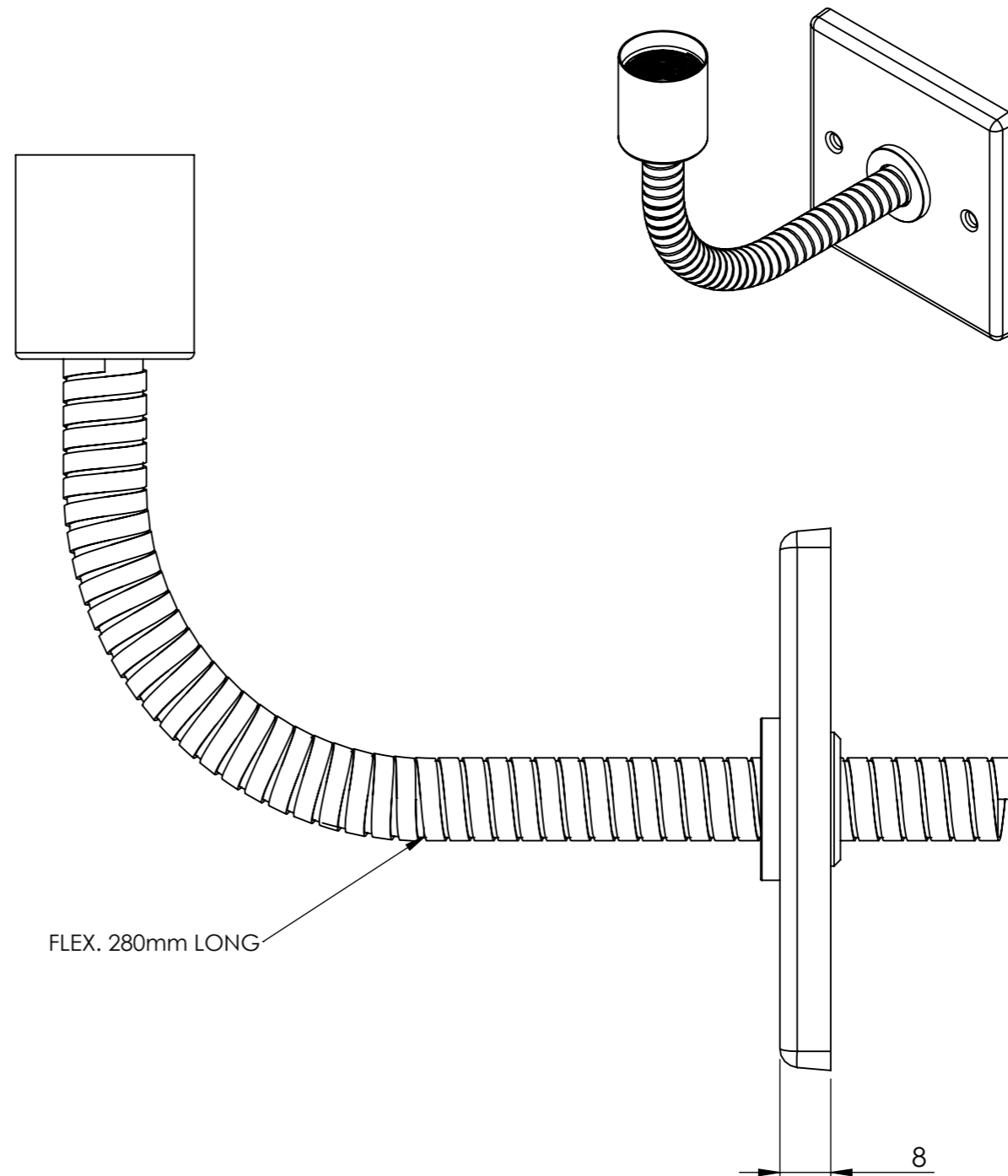
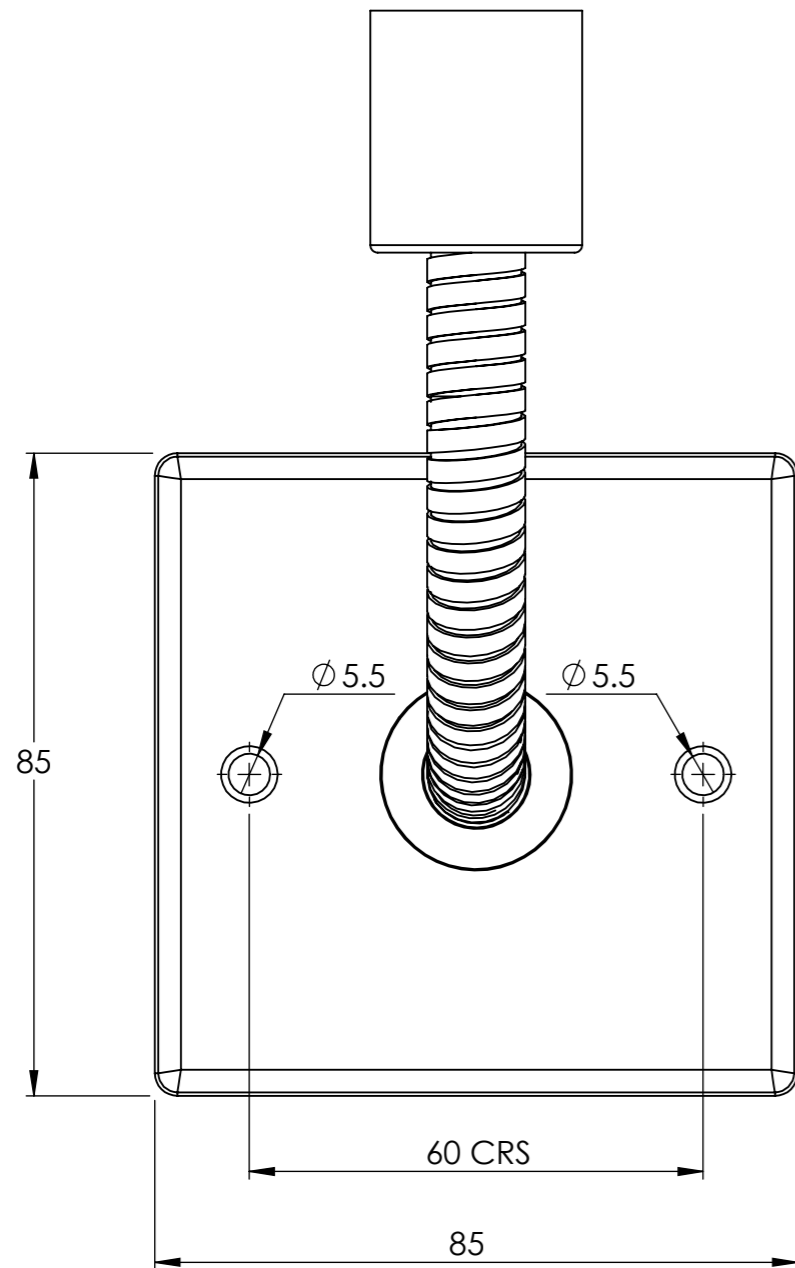

**FINISH TO MATCH WITH CHOSEN RAIL**

DO NOT SCALE DRAWING ALL DIMENSIONS ARE IN MILLIMETERS AND MAY VARY ± 5mm AS THEY ARE HANDMADE, HAND SOLDERED AND POLISHED  
WE THEREFORE RECOMMEND THAT ANY INSTALLATION WORK BE CARRIED OUT UPON RECEIPT OF RAIL.

BARD & BRAZIER LIMITED T: +44 (0) 121 270 2222  
MARSTON ROAD E: INFO@BARDBRAZIER.CO.UK  
WOLVERHAMPTON  
WEST MIDLANDS WWW.BARDBRAZIER.CO.UK  
WV2 4LX  
UK

BARD & BRAZIER RAILS ARE MADE IN ENGLAND  
FROM HIGH QUALITY BRASS

TITLE:  
ELECTRICAL KIT ASSEMBLY



SCALE: 1:1 DATE: 07/08/2018

PRODUCT CODE:  
E201



BARD & BRAZIER

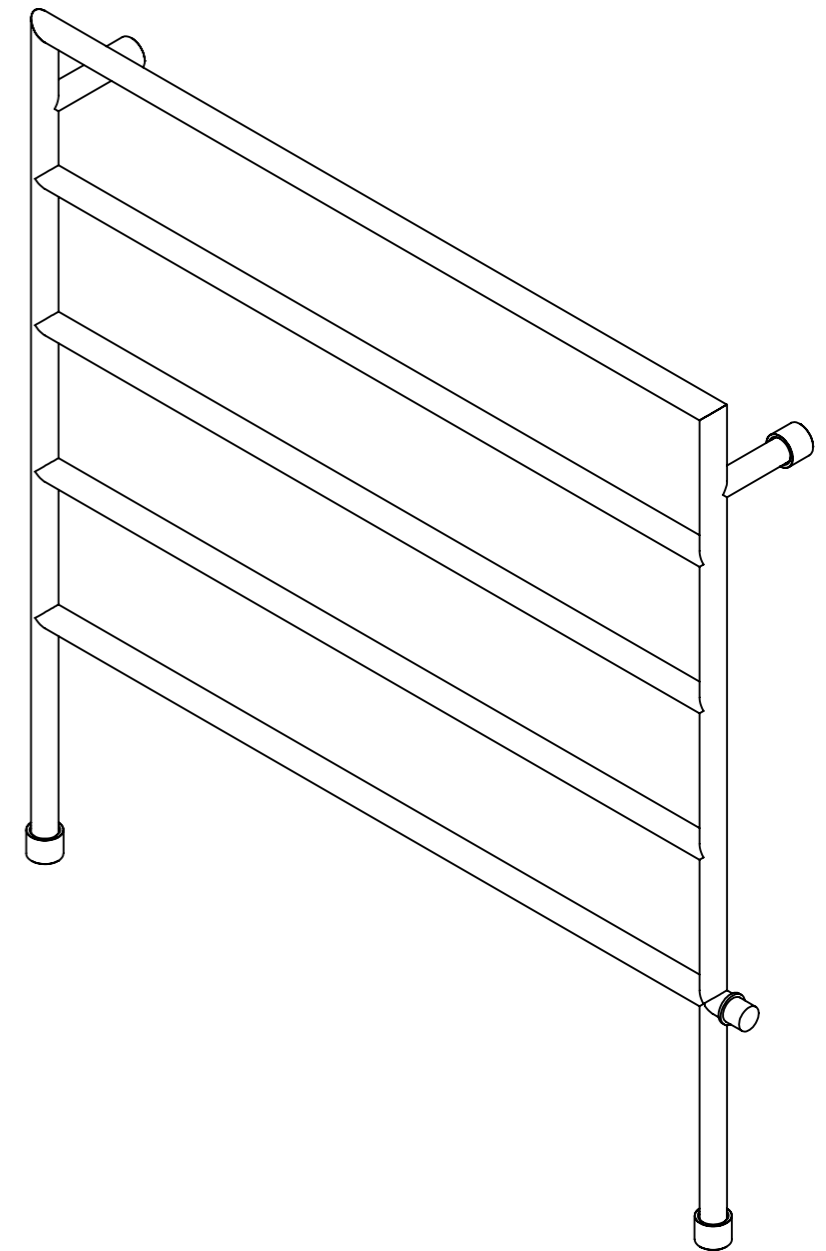
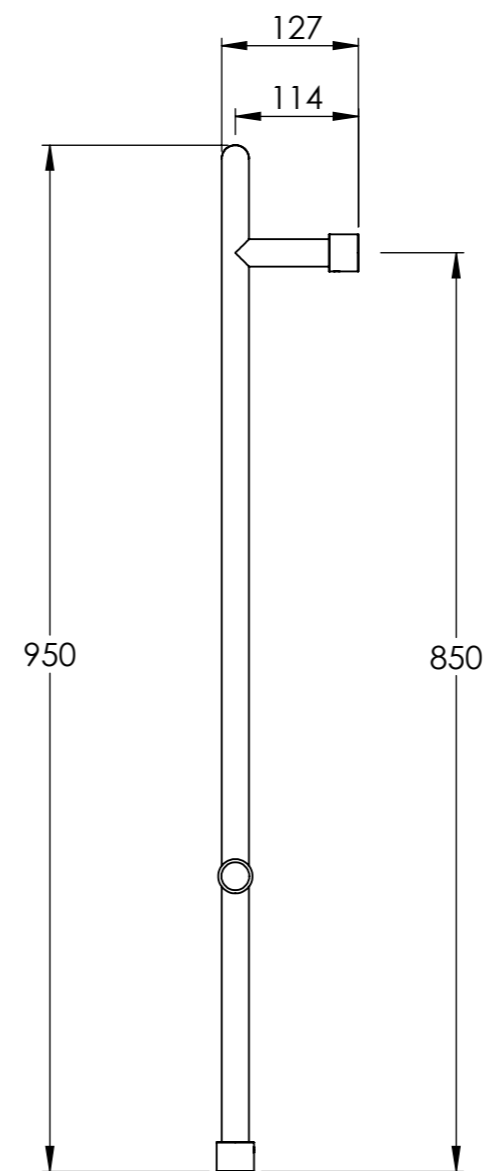
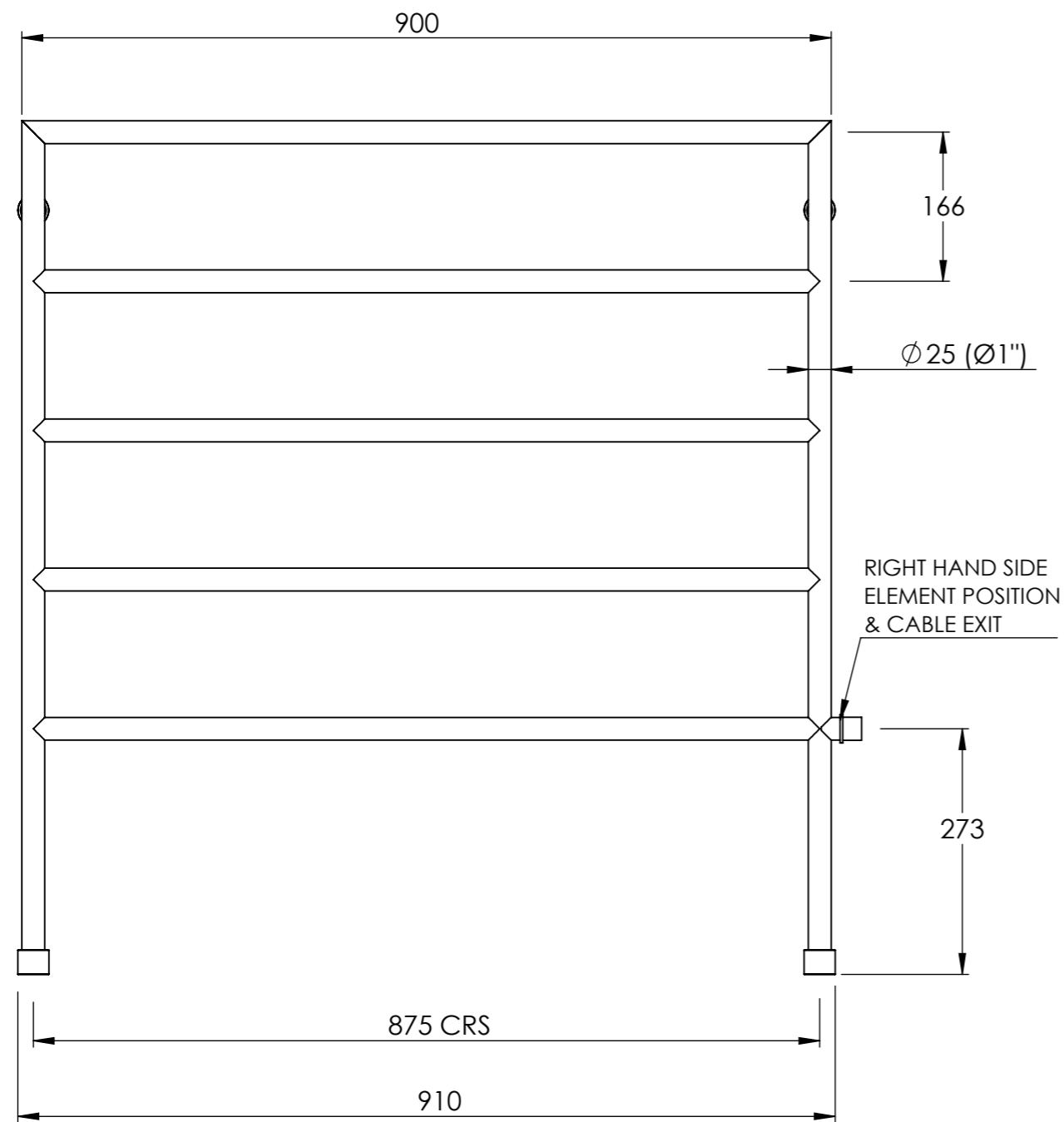

REFER TO PAGE 2 FOR ELECTRICAL CONNECTION AND COVER PLATE SPECIFICATION

DO NOT SCALE DRAWING ALL DIMENSIONS ARE IN MILLIMETERS AND MAY VARY  $\pm 5$ mm AS THEY ARE HANDMADE, HAND SOLDERED AND POLISHED

WE THEREFORE RECOMMEND THAT ANY INSTALLATION WORK BE CARRIED OUT UPON RECEIPT OF RAIL.

BTU/HR AT DELTA 60:	1040	TEST PRESSURE:	6 BAR
ELECTRICAL ELEMENT WATTAGE:	100	MAX WORKING TEMPERATURE:	100°C
HEAT OUTPUT DETERMINED IN ACCORDANCE WITH EN 442			
BARD & BRAZIER LIMITED MARSTON ROAD WOLVERHAMPTON WEST MIDLANDS WV2 4LX UK		T: +44 (0) 121 270 2222 E: INFO@BARDBRAZIER.CO.UK WWW.BARDBRAZIER.CO.UK	
TITLE: D-RAIL 5 BAR TOWEL WARMER 950 x 900mm - SEALED ELECTRIC			
BARD & BRAZIER RAILS ARE MADE IN ENGLAND FROM HIGH QUALITY BRASS		SCALE:	DATE:
		1:7	16/04/2018
 BARD & BRAZIER		PRODUCT CODE:	
		DRF95-90SE	



BARD & BRAZIER

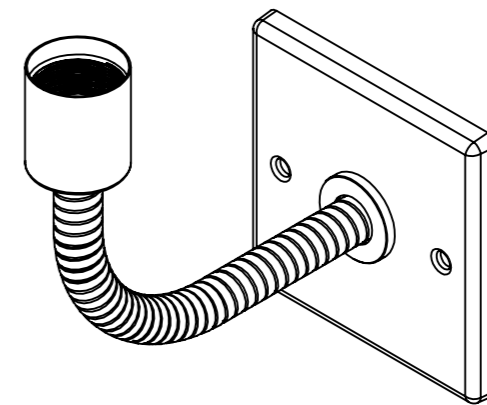
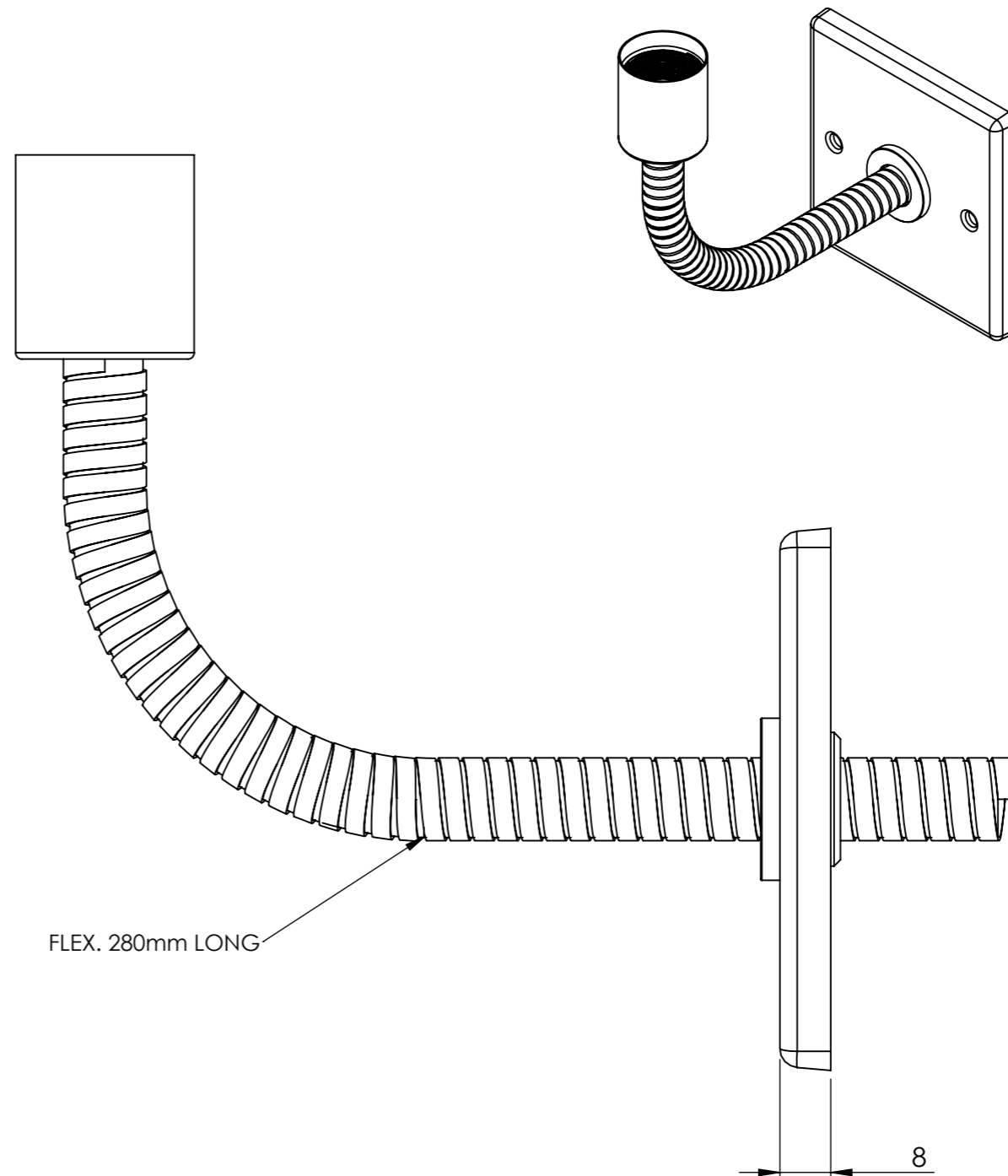
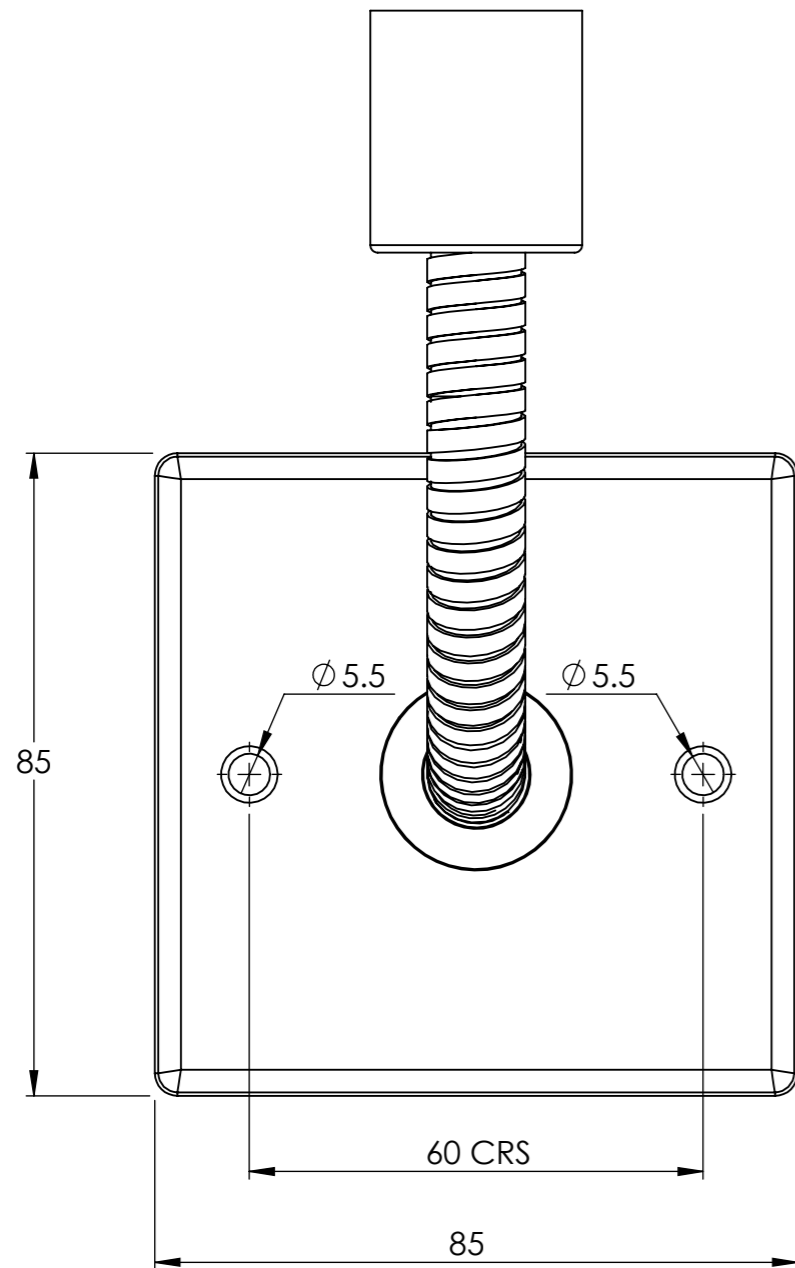

**FINISH TO MATCH WITH CHOSEN RAIL**

DO NOT SCALE DRAWING ALL DIMENSIONS ARE IN MILLIMETERS AND MAY VARY ± 5mm AS THEY ARE HANDMADE, HAND SOLDERED AND POLISHED

WE THEREFORE RECOMMEND THAT ANY INSTALLATION WORK BE CARRIED OUT UPON RECEIPT OF RAIL.

BARD & BRAZIER LIMITED T: +44 (0) 121 270 2222  
 MARSTON ROAD E: INFO@BARDBRAZIER.CO.UK  
 WOLVERHAMPTON  
 WEST MIDLANDS WWW.BARDBRAZIER.CO.UK  
 WV2 4LX  
 UK

BARD & BRAZIER RAILS ARE MADE IN ENGLAND FROM HIGH QUALITY BRASS

TITLE:  
ELECTRICAL KIT ASSEMBLY



SCALE: 1:1  
 DATE: 07/08/2018

PRODUCT CODE:  
E201