

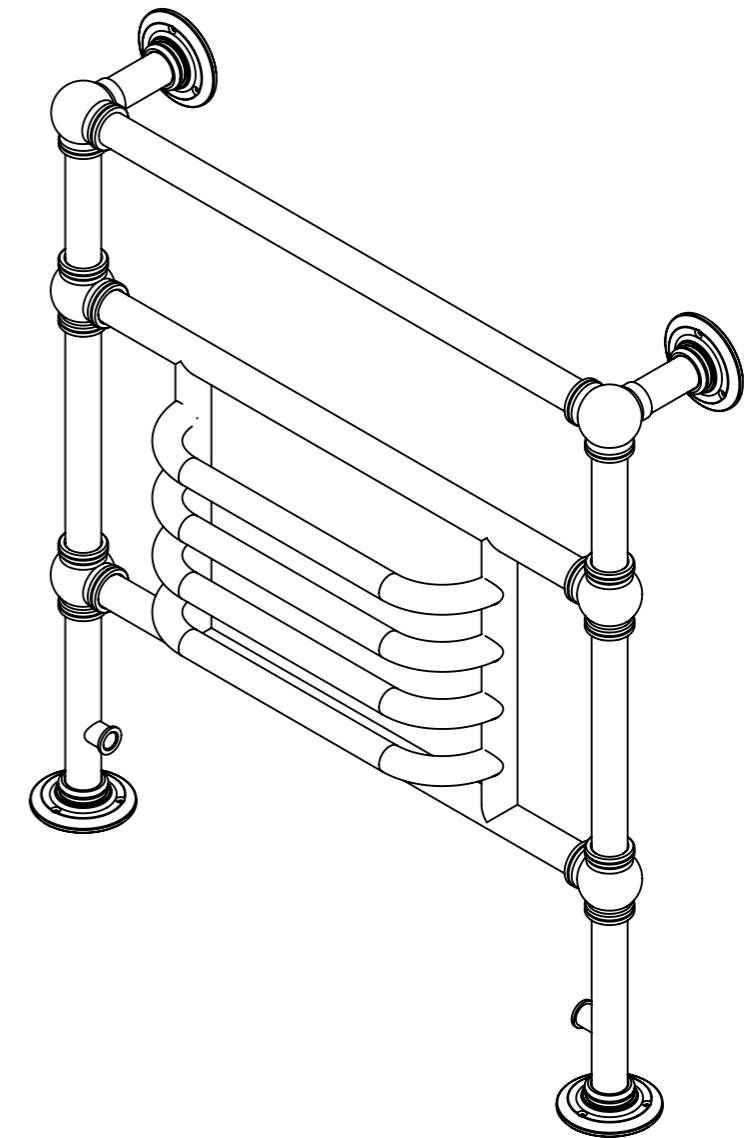

BARD & BRAZIER

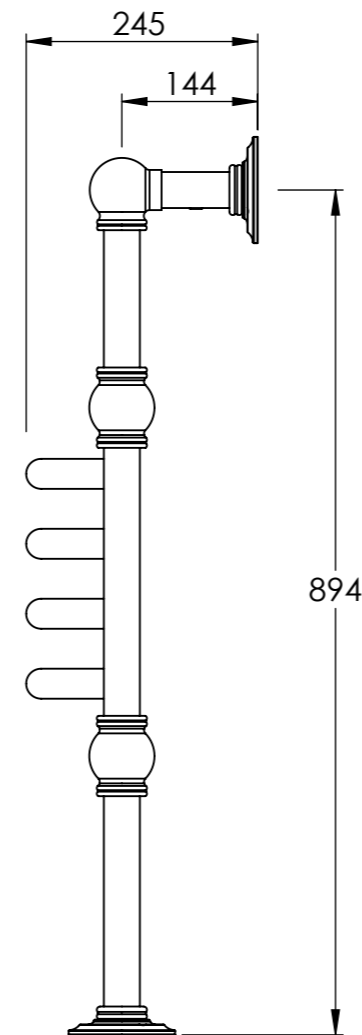
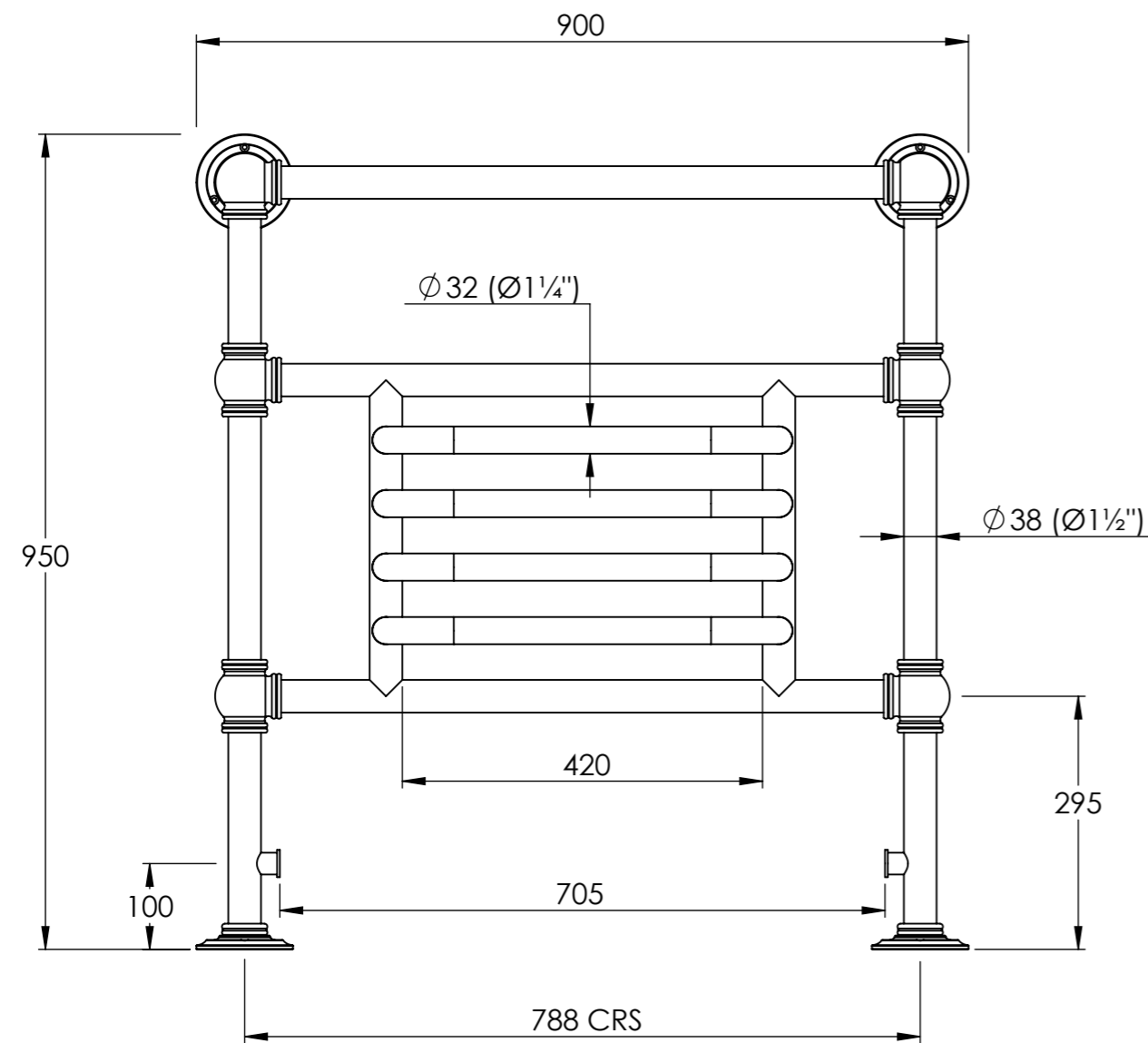

DO NOT SCALE DRAWING ALL DIMENSIONS ARE IN MILLIMETERS AND MAY VARY  $\pm 5$ mm AS THEY ARE HANDMADE, HAND SOLDERED AND POLISHED  
 WE THEREFORE RECOMMEND THAT ANY INSTALLATION WORK BE CARRIED OUT UPON RECEIPT OF RAIL.

BTU/HR AT DELTA 60:	3057	TEST PRESSURE:	6 BAR
CONNECTIONS:	FI $\frac{1}{2}$ " BSP	MAX WORKING PRESSURE:	3 BAR
		MAX WORKING TEMPERATURE:	100°C
HEAT OUTPUT DETERMINED IN ACCORDANCE WITH EN 442			
BARD & BRAZIER LIMITED MARSTON ROAD WOLVERHAMPTON WEST MIDLANDS WV2 4LX UK		T: +44 (0) 121 270 2222 E: INFO@BARDBRAZIER.CO.UK WWW.BARDBRAZIER.CO.UK	
		TITLE: BARONIAL GRILLE FLOOR MOUNTED TOWEL RAIL 950mm x 900mm - HYDRONIC	
		SCALE: 1:8	DATE: 17/02/2022
		PRODUCT CODE: BGF95-90	

BARD & BRAZIER RAILS ARE MADE IN ENGLAND  
 FROM HIGH QUALITY BRASS AND CAN BE USED  
 ON OPEN OR CLOSED CIRCUITS





BARD & BRAZIER

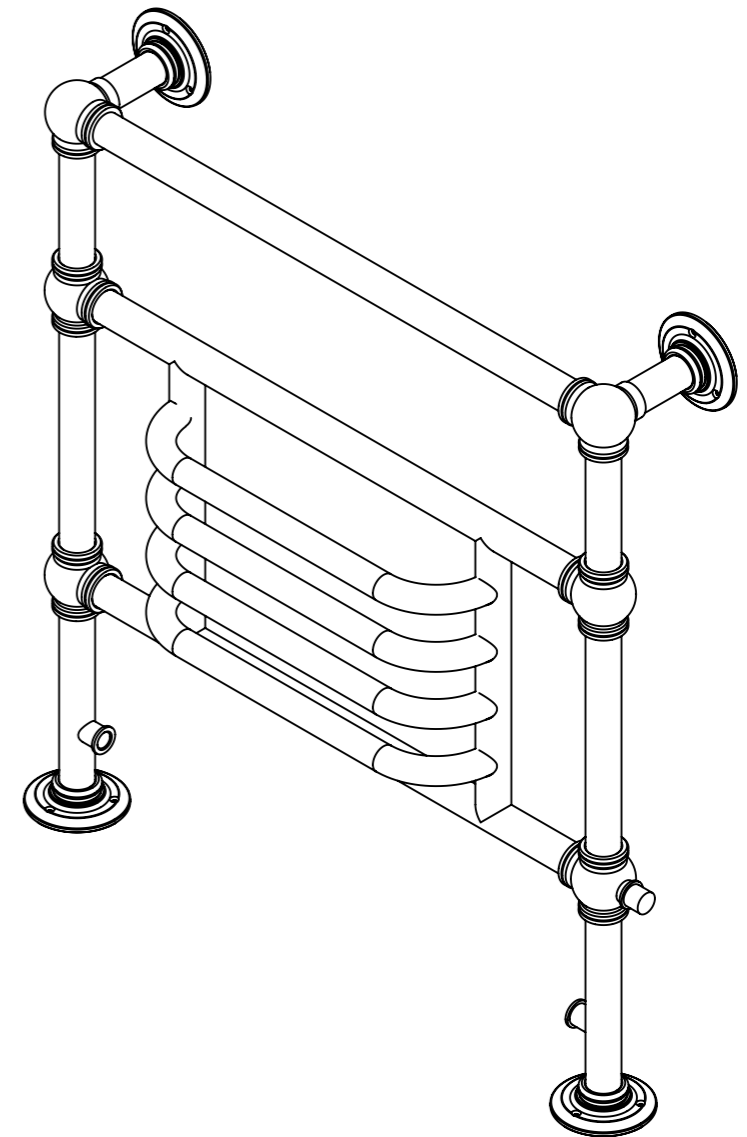
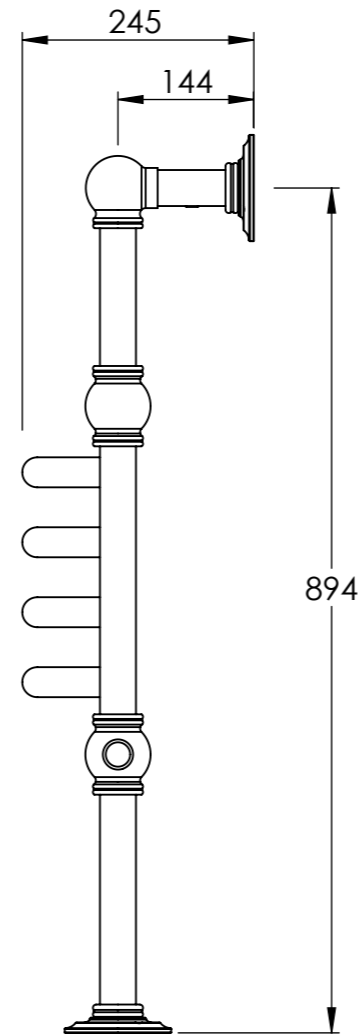
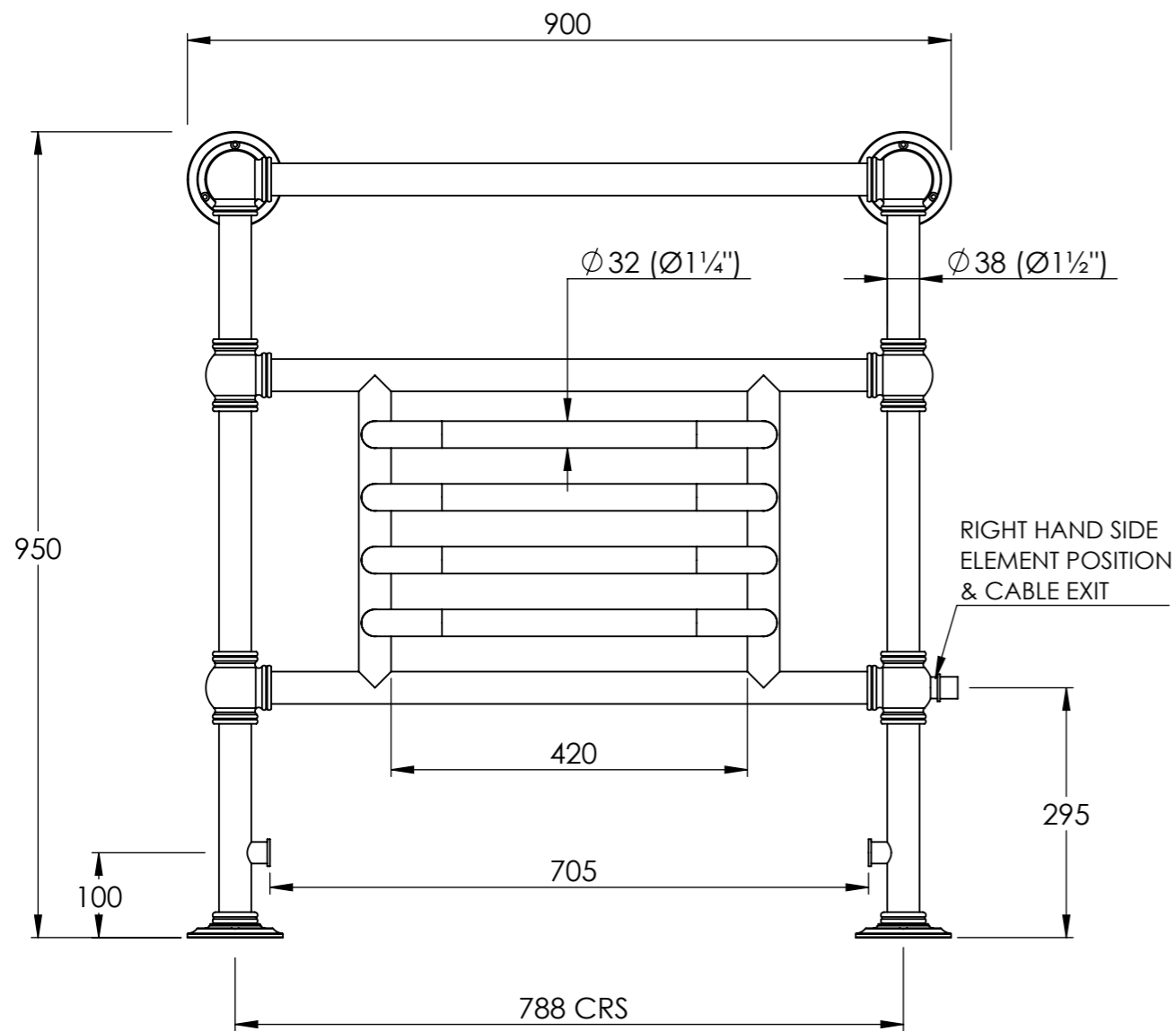

REFER TO PAGE 2 FOR ELECTRICAL CONNECTION AND CABLE COVER SPECIFICATION

DO NOT SCALE DRAWING ALL DIMENSIONS ARE IN MILLIMETERS AND MAY VARY  $\pm 5$ mm AS THEY ARE HANDMADE, HAND SOLDERED AND POLISHED

WE THEREFORE RECOMMEND THAT ANY INSTALLATION WORK BE CARRIED OUT UPON RECEIPT OF RAIL.

BTU/HR AT DELTA 60:	3057	TEST PRESSURE:	6 BAR
ELECTRICAL ELEMENT WATTAGE:	250	MAX WORKING TEMPERATURE:	100°C
		CONNECTIONS	FI 1/2" BSP
HEAT OUTPUT DETERMINED IN ACCORDANCE WITH EN 442			
BARD & BRAZIER LIMITED MARSTON ROAD WOLVERHAMPTON WEST MIDLANDS WV2 4LX UK		T: +44 (0) 121 270 2222 E: INFO@BARDBRAZIER.CO.UK WWW.BARDBRAZIER.CO.UK	
TITLE: BARONIAL GRILLE FLOOR MOUNTED TOWEL RAIL 950mm x 900mm - DUAL FUEL			
BARD & BRAZIER		SCALE:	DATE:
		1:8	17/02/2022
		PRODUCT CODE: BGF95-90DF	

BARD & BRAZIER RAILS ARE MADE IN ENGLAND FROM HIGH QUALITY BRASS AND CAN BE USED ON OPEN OR CLOSED CIRCUITS



BARD & BRAZIER

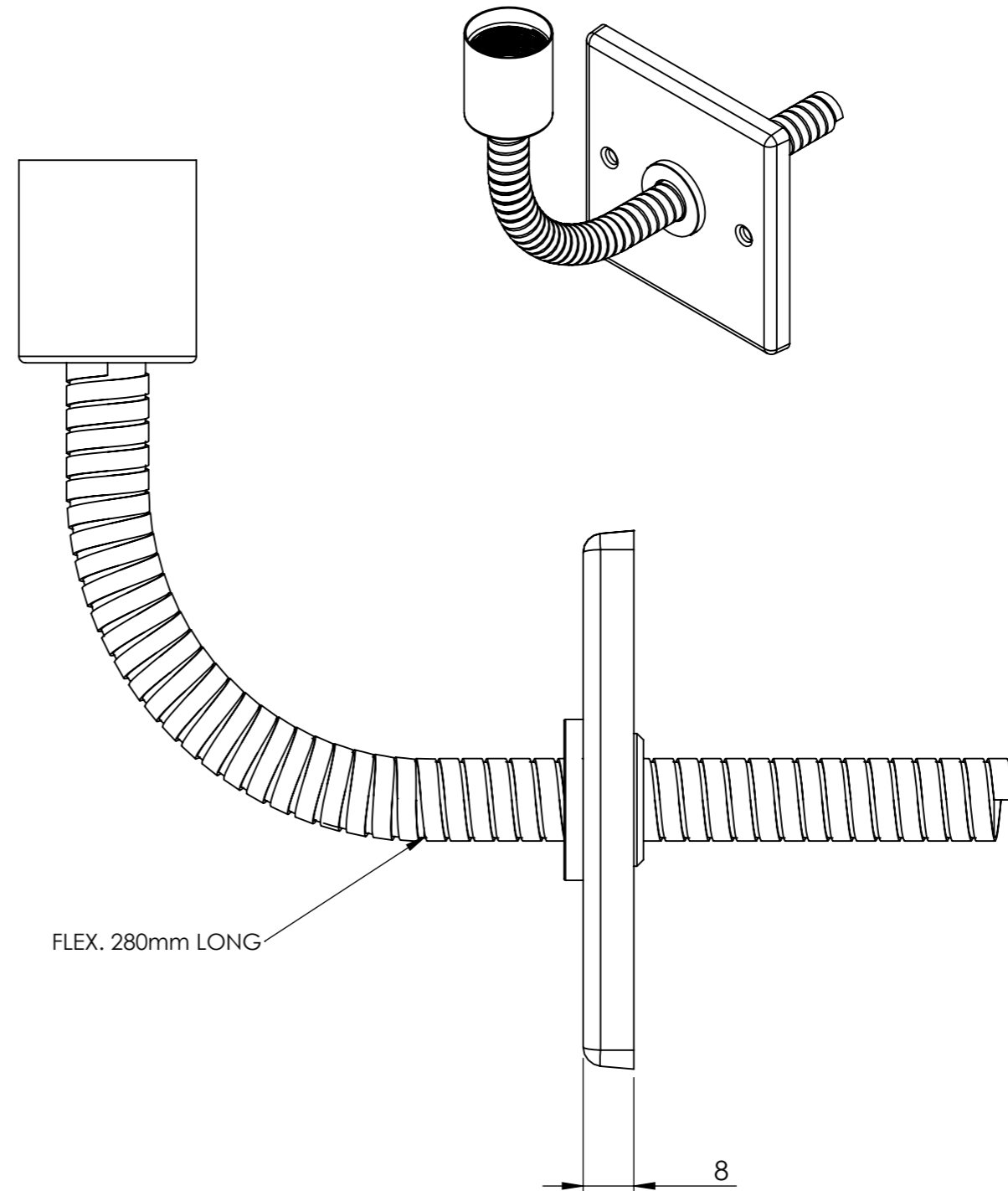
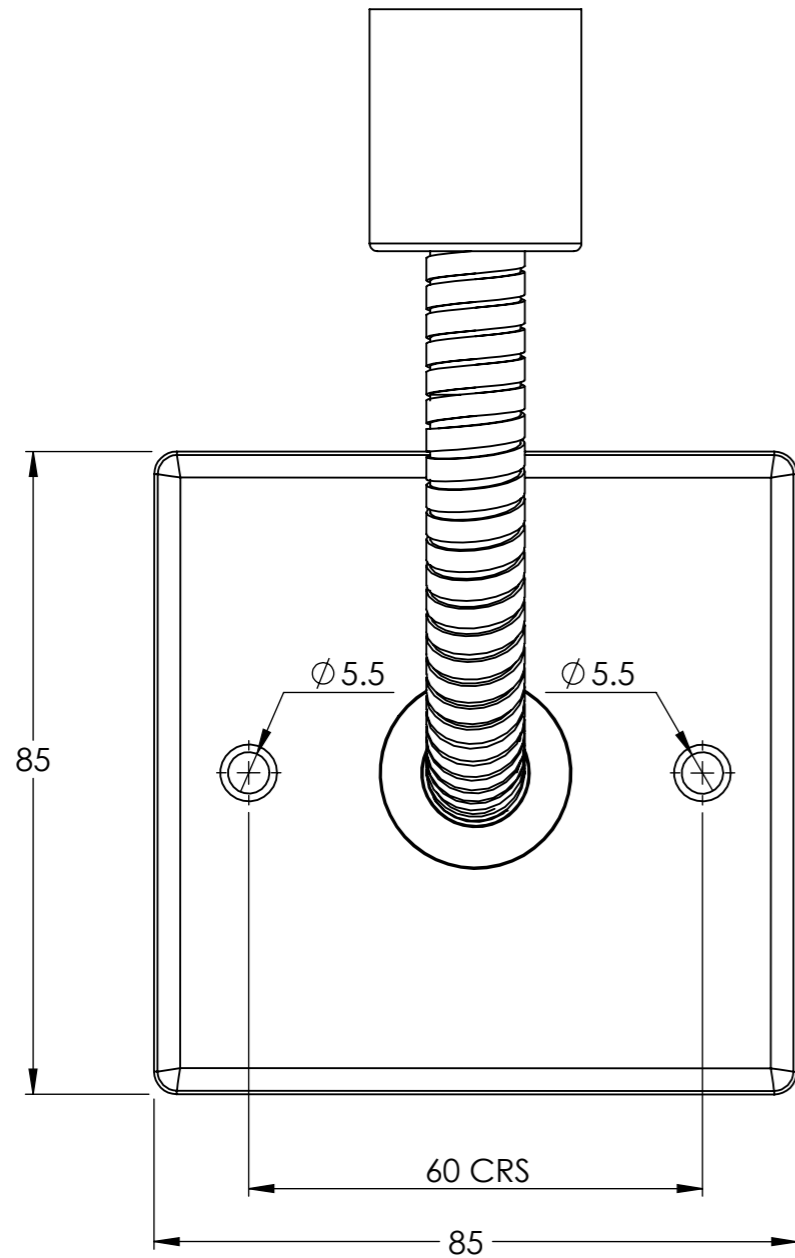

**FINISH TO MATCH WITH CHOSEN RAIL**

DO NOT SCALE DRAWING ALL DIMENSIONS ARE IN MILLIMETERS AND MAY VARY ± 5mm AS THEY ARE HANDMADE, HAND SOLDERED AND POLISHED  
WE THEREFORE RECOMMEND THAT ANY INSTALLATION WORK BE CARRIED OUT UPON RECEIPT OF RAIL.

BARD & BRAZIER LIMITED T: +44 (0) 121 270 2222  
MARSTON ROAD E: INFO@BARDBRAZIER.CO.UK  
WOLVERHAMPTON  
WEST MIDLANDS WWW.BARDBRAZIER.CO.UK  
WV2 4LX  
UK

BARD & BRAZIER RAILS ARE MADE IN ENGLAND  
FROM HIGH QUALITY BRASS

TITLE:  
ELECTRICAL KIT ASSEMBLY



SCALE: 1:1  
DATE: 07/08/2018  
PRODUCT CODE: E201



BARD & BRAZIER

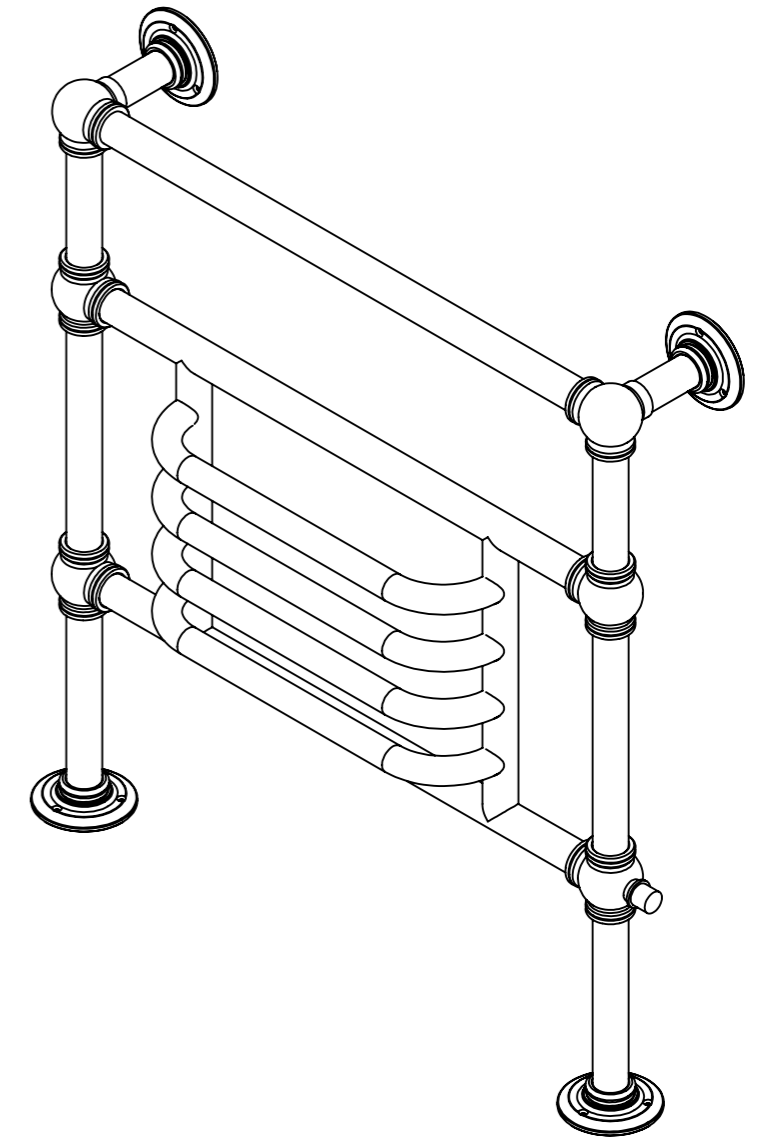
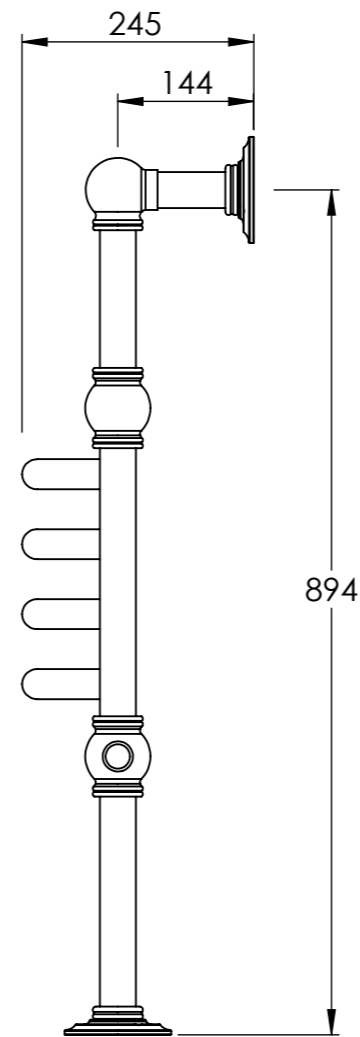
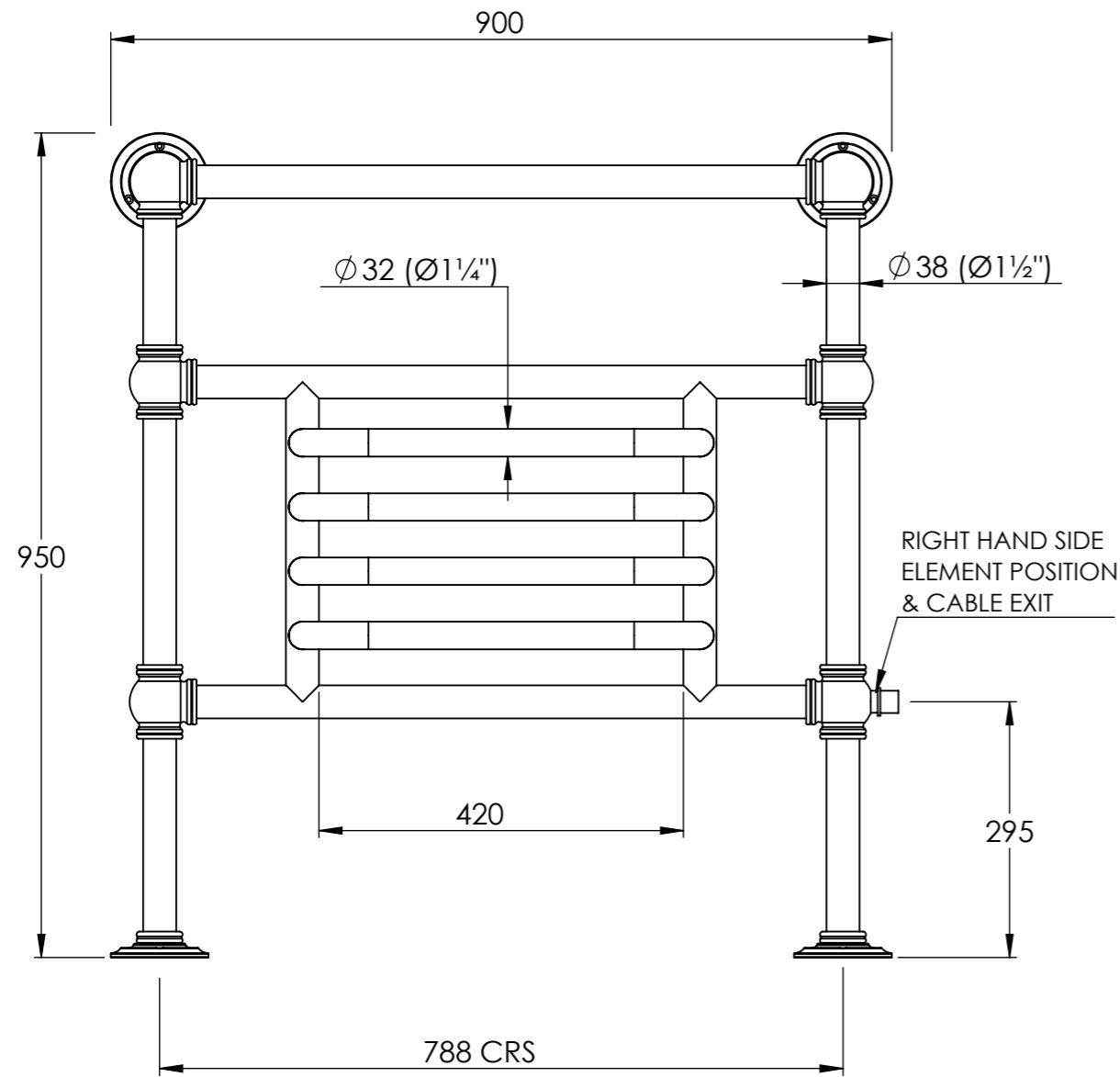

**REFER TO PAGE 2 FOR ELECTRICAL CONNECTION AND COVER PLATE SPECIFICATION**

DO NOT SCALE DRAWING ALL DIMENSIONS ARE IN MILLIMETERS AND MAY VARY ± 5mm AS THEY ARE HANDMADE, HAND SOLDERED AND POLISHED  
WE THEREFORE RECOMMEND THAT ANY INSTALLATION WORK BE CARRIED OUT UPON RECEIPT OF RAIL.

BTU/HR AT DELTA 60:	3057	TEST PRESSURE:	6 BAR
ELECTRICAL ELEMENT WATTAGE:	250	MAX WORKING TEMPERATURE:	100°C
HEAT OUTPUT DETERMINED IN ACCORDANCE WITH EN 442			
BARD & BRAZIER LIMITED MARSTON ROAD WOLVERHAMPTON WEST MIDLANDS WV2 4LX UK		T: +44 (0) 121 270 2222 E: INFO@BARDBRAZIER.CO.UK WWW.BARDBRAZIER.CO.UK	
<b>TITLE:</b> BARONIAL GRILLE FLOOR MOUNTED TOWEL RAIL 950mm x 900mm - SEALED ELECTRIC			
BARD & BRAZIER RAILS ARE MADE IN ENGLAND FROM HIGH QUALITY BRASS		SCALE:	DATE:
		1:8	16/04/2018
 <b>BARD &amp; BRAZIER</b>		PRODUCT CODE:	
		BGF95-90SE	



BARD & BRAZIER

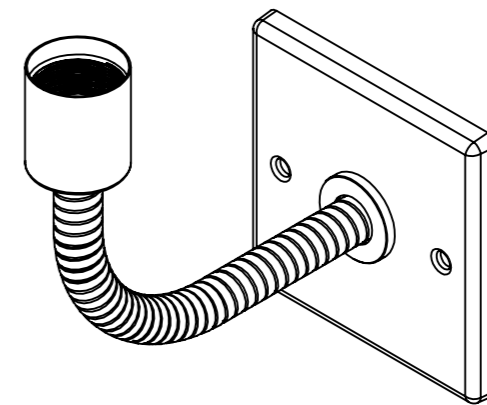
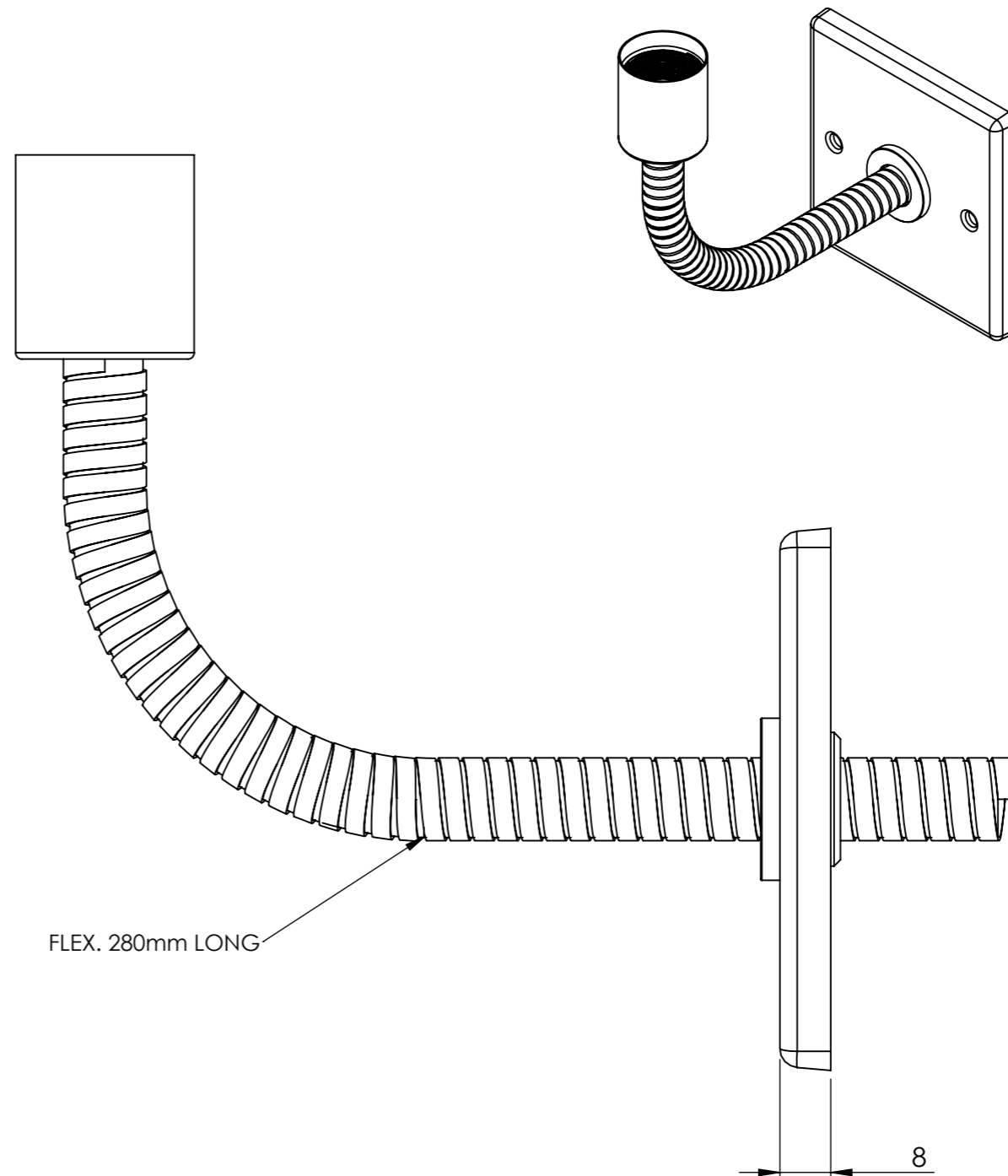
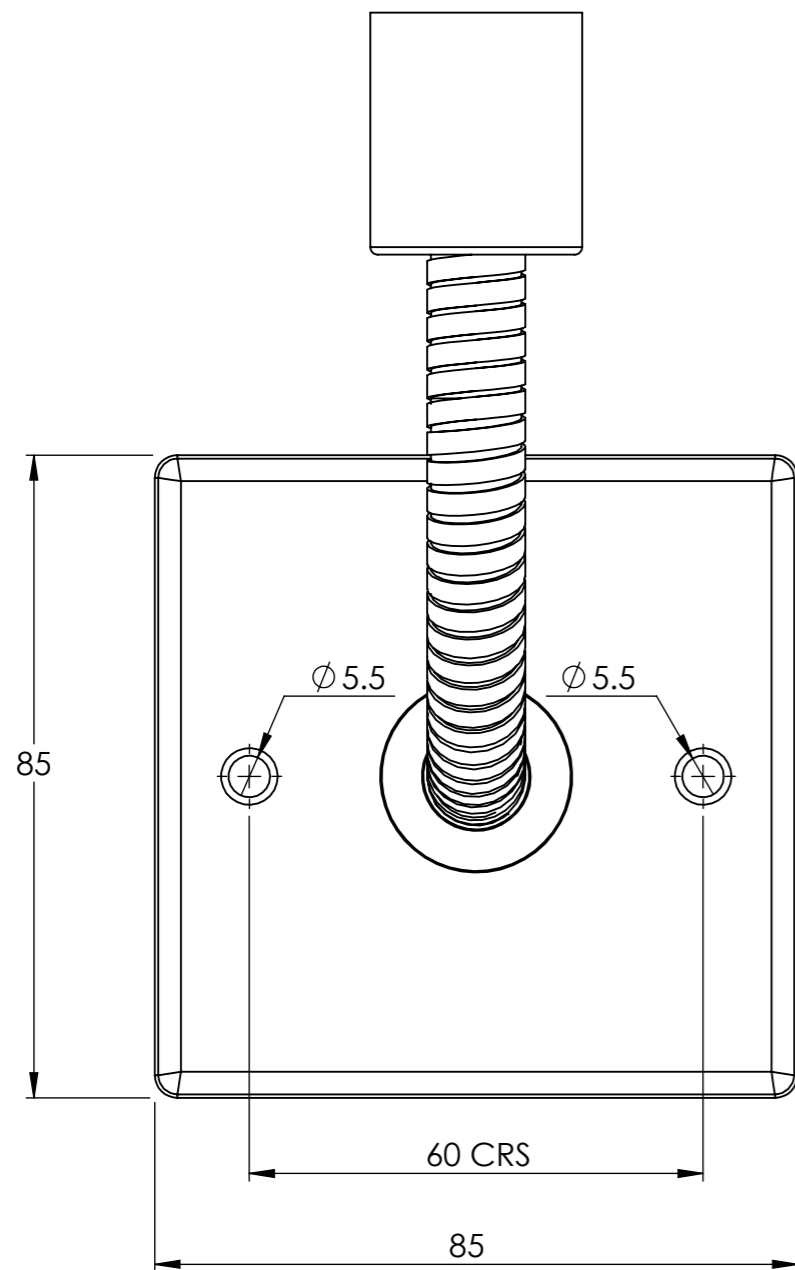

**FINISH TO MATCH WITH CHOSEN RAIL**

DO NOT SCALE DRAWING ALL DIMENSIONS ARE IN MILLIMETERS AND MAY VARY ± 5mm AS THEY ARE HANDMADE, HAND SOLDERED AND POLISHED

WE THEREFORE RECOMMEND THAT ANY INSTALLATION WORK BE CARRIED OUT UPON RECEIPT OF RAIL.

BARD & BRAZIER LIMITED T: +44 (0) 121 270 2222  
 MARSTON ROAD E: INFO@BARDBRAZIER.CO.UK  
 WOLVERHAMPTON  
 WEST MIDLANDS WWW.BARDBRAZIER.CO.UK  
 WV2 4LX  
 UK

BARD & BRAZIER RAILS ARE MADE IN ENGLAND  
 FROM HIGH QUALITY BRASS

TITLE:  
 ELECTRICAL KIT ASSEMBLY



SCALE: 1:1 DATE: 07/08/2018

PRODUCT CODE:  
 E201